

FIND *your* HAPPY PACE



PALM DESERT  
CALIFORNIA

# City of Palm Desert Master Plan

Signage & Wayfinding Master Plan Report

January 05, 2025

Selbert  
Perkins  
Design.

# Table of Contents

Table of Contents	2	<b>Sign Details</b>	26
Goals & Objectives	3	Color, Materials, Type, & Symbols	27
How to Use Document	4	<i>Color</i>	27
<b>Planning &amp; Strategic Insights</b>	5	<i>Materials</i>	28
Analysis	6	<i>Type</i>	29
<i>Site Map</i>	6	<i>Symbols</i>	30
<i>Demographics</i>	7	<b>Detail Drawings</b>	31
<i>Citywide Circulation</i>	8	<i>A01 - Gateway Monument 1</i>	31
<i>El Paseo Circulation</i>	9	<i>A02 - Gateway Monument 2</i>	32
<i>Existing SLP</i>	10	<i>A03 - Gateway Monument 3</i>	33
S.W.O.T. Analysis	15	<i>B01 - Vehicle Direction Large</i>	34
Recommendations	16	<i>B02 - Vehicle Direction Medium</i>	35
<b>City of Palm Desert Branding</b>	17	<i>B03 - Vehicle Direction Small</i>	36
Branding	18	<i>B04 - Pedestrian Directory Static</i>	37
<b>Signage Overview</b>	19	<b>Sign Location Plan</b>	38
Signage	20	Sign Location Plan (In Progress)	39
<i>Summary of Signs</i>	20	<b>Specifications</b>	45
<i>Concept Moodboard</i>	21	Specifications	46
<i>Family of Signs</i>	22		
<i>Renderings</i>	24		

## Goals & Objectives

**Design a refreshed wayfinding system that captures the artistic, vibrant, desert city of Palm Desert and it's inhabitants — be they visitor or resident.**

- Provides **Clear Navigation** for residents and visitors, directing them to essential civic and community locations such as parks, schools, City buildings, facilities, and local attractions
- Establishes **Consistent and Unified design** criteria for directional signage that embodies the unique identity of Palm Desert.
- Enhances and updates wayfinding system to **accurately represent points of interest** and the incorporation of new signs where necessary.
- **Attracts New Audiences** through modern branding and design, which will directly promote development in Palm Desert.
- **A Flexible Master Plan** that can be expanded and adapted to meet the needs of various city departments and projects.



## How to Use Document

The City of Palm Desert Master Plan manual provides uniform and consistent wayfinding signage guidelines and serves as the master reference for City of Palm Desert employees, residents and visitors.

- **Summary of Signs**

Presents approved signs in a comprehensive matrix index for quick reference.

- **General Information**

Provides an overview of City of Watsonville signage and wayfinding program, as well as park and trail types with corresponding sign types per type.

- **Graphic Standards**

Specifies typography, patterns, pictograms, direction arrows, and materials guidelines for the signage and wayfinding program.

- **Sign Type Design Details**

Details the design intent of individual signs with drawings and notes.

- **Specifications**

Includes general performance specifications for fabrication.

- **Contact**

Questions about wayfinding and signage may be directed to Chris Gerry.

Chris Gerry  
cgerry@palmdesert.gov  
73510 Fred Waring  
Palm Desert, CA 92260



# Planning & Strategic Insights

# Analysis

## Site Map

Scope of work for City of Palm Desert Wayfinding Master Plan.

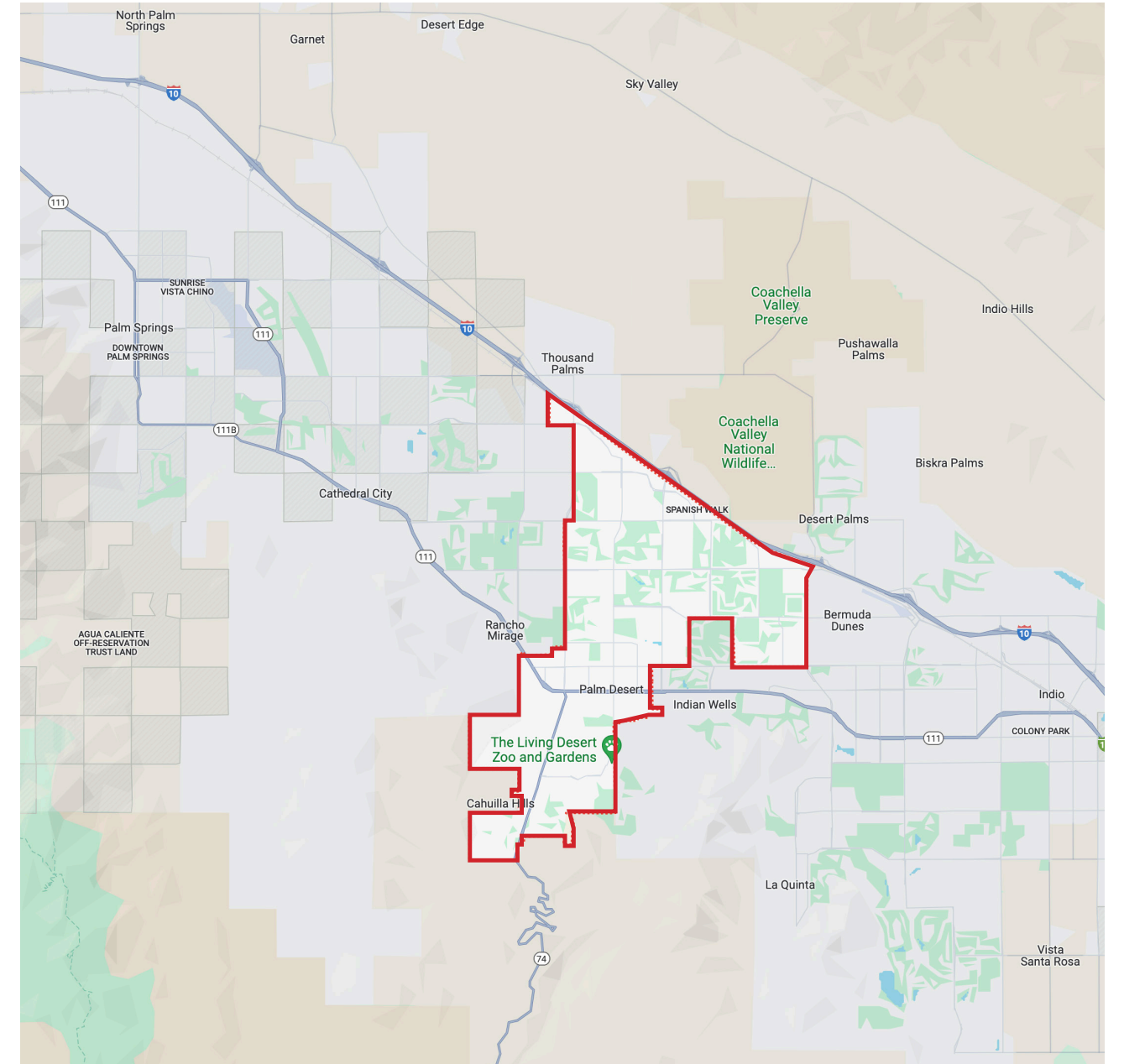

# Analysis

## Demographics

Research shows demographics of City of Palm Desert residents.



### Demographics

White	70.8%
Black or African American	2.9%
American Indian and Alaska Native	0.7%
Asian alone	4.3%
Native Hawaiian and Other Pacific Islander	0.3%
Two or More Races	13.4%
Hispanic or Latino	24.0%
White alone, not Hispanic or Latino	65.0%

### Population of 51,583 (2022)

Persons under 5 years, percent	3.1%
Persons under 18 years, percent	14.2%
Persons 65 years and over, percent	36.1%

**The median age was 55.1 years old.**

# Analysis

## Citywide Circulation

Site circulation reveals primary and secondary routes—how people approach, enter, and move within a space. It includes pathways taken by pedestrians, vehicles, cyclists, and even maintenance vehicles.

By understanding these key routes, we can position signs at critical junctions, intersections, and decision points, ensuring visibility and relevance.

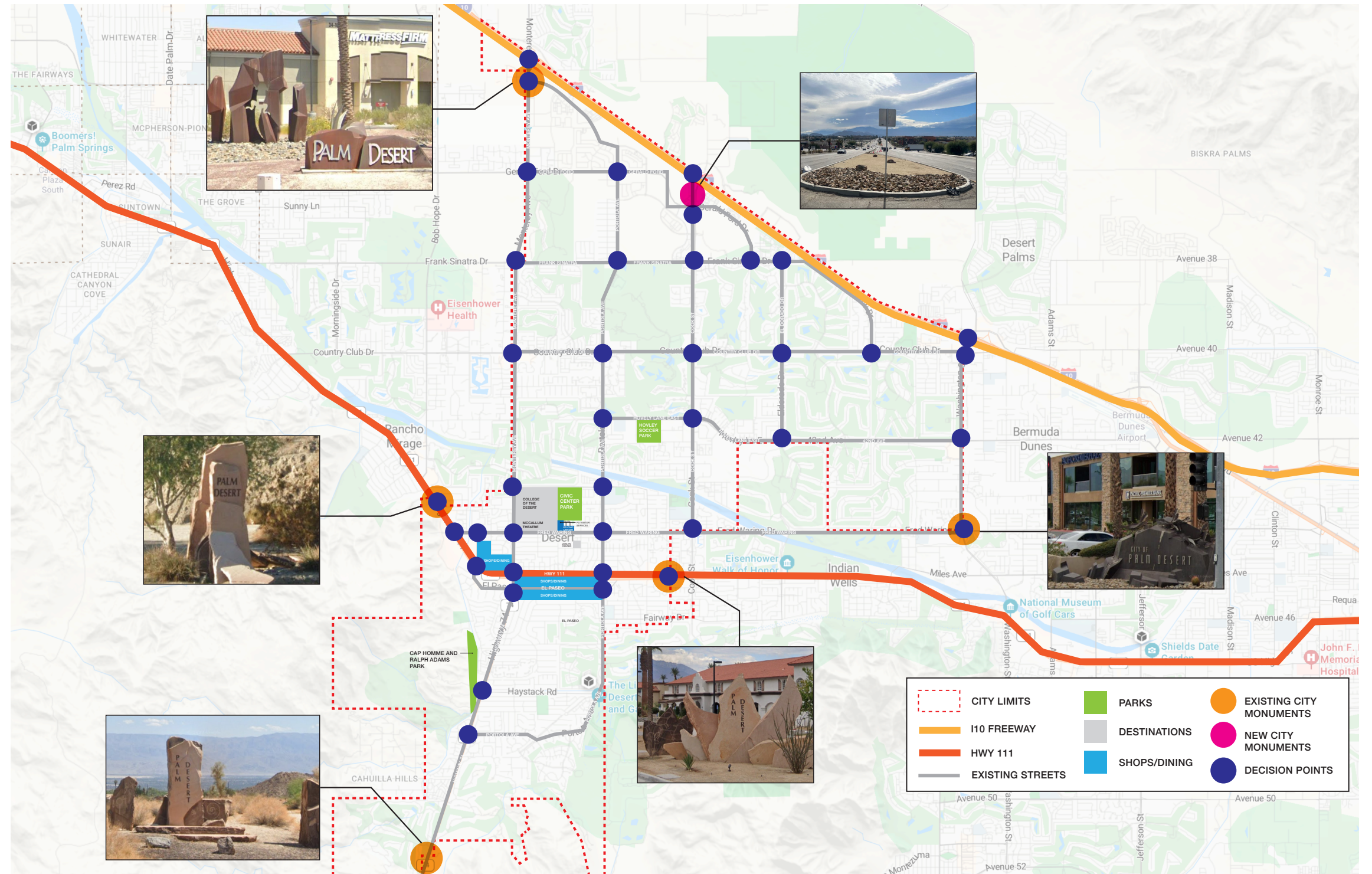

# Analysis

## El Paseo Circulation



# Analysis

## Existing SLP

The following pages provide an inventory of existing sign locations across the City of Palm Desert. For clarity, the signs have been organized into four quadrants. Each sign is assigned a tag number that corresponds to its type, description, quantity, and accompanying image.

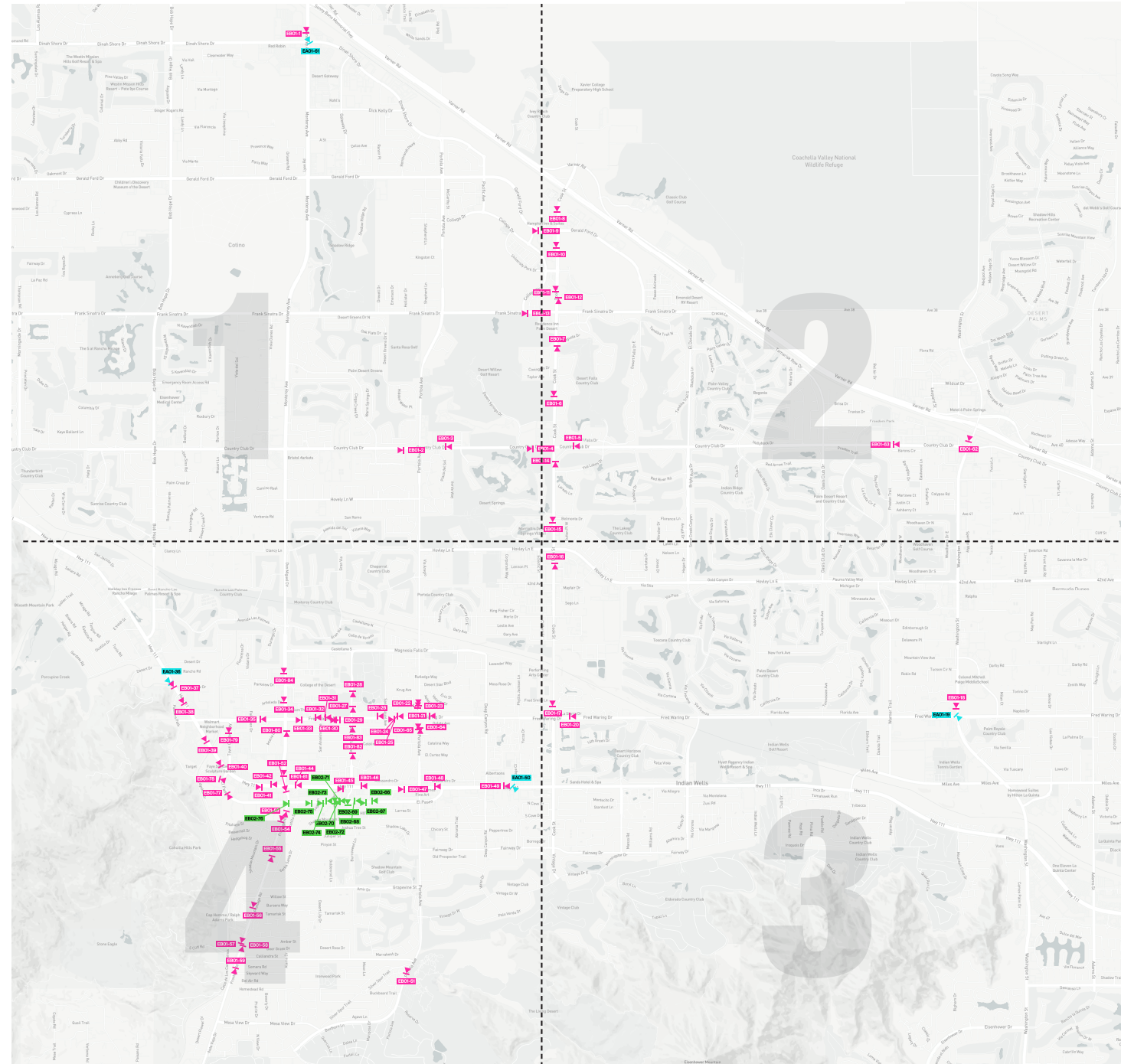

Type	Description	Qty.
<b>Citywide Wayfinding</b>		
EA01	Existing Monument Sign	4
EB02	Existing Parking Directional	11
EB01	Existing Vehicular Directional	67
<b>SUB-TOTAL</b>		<b>82</b>

# Analysis

## Existing SLP

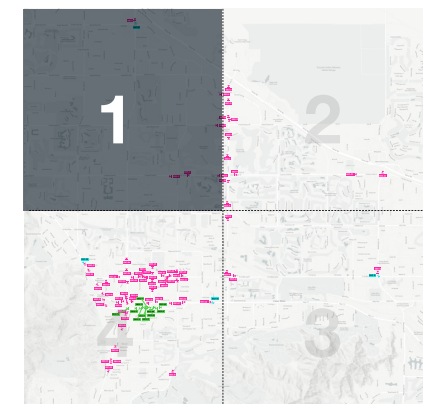
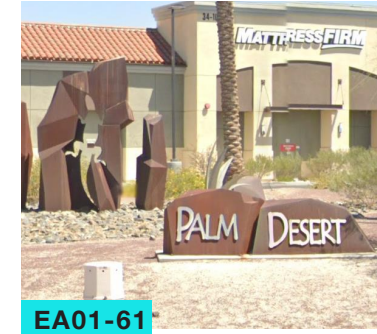
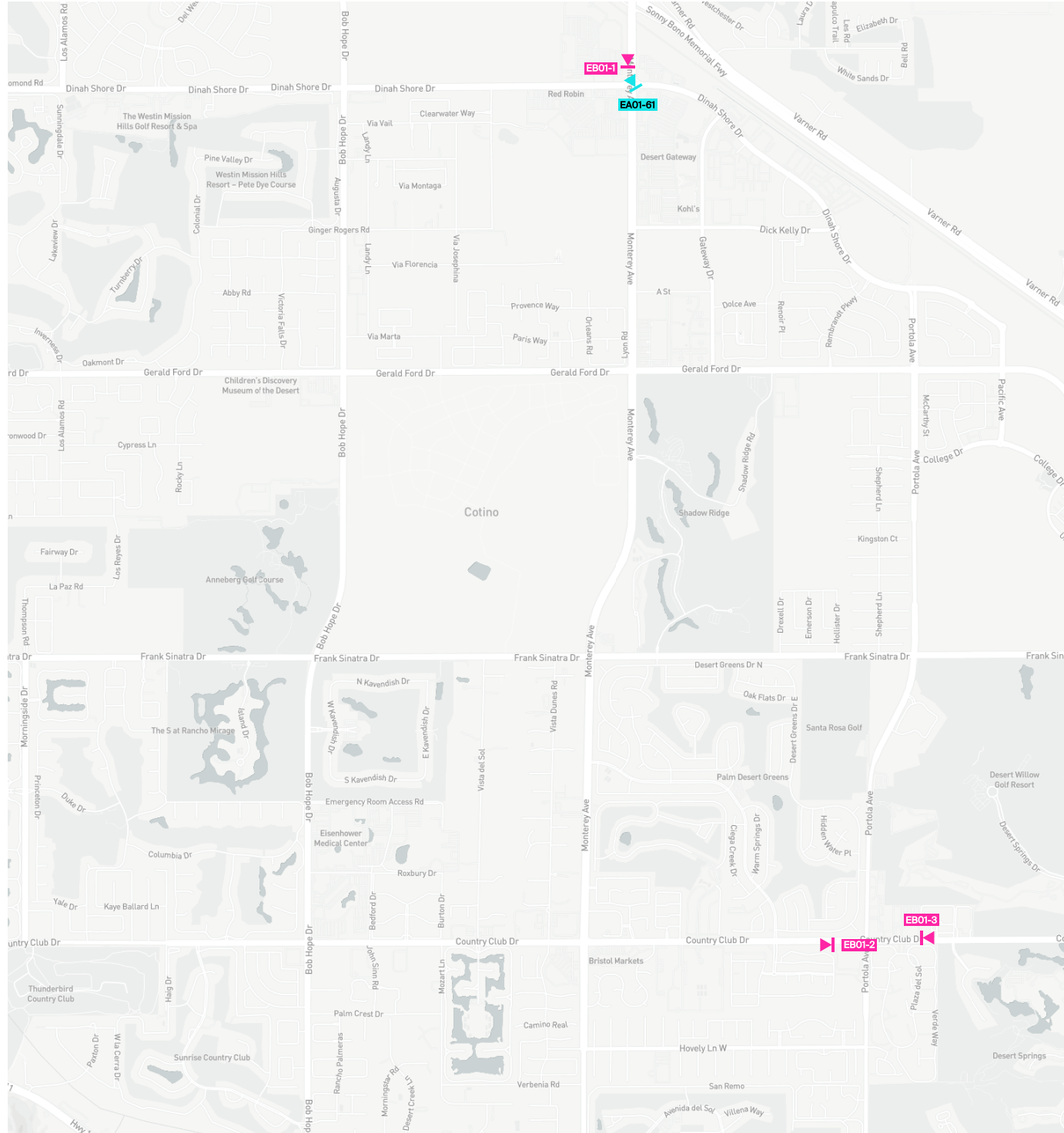

Type	Description	Qty.
<b>Citywide Wayfinding</b>		
EA01	Existing Monument Sign	4
EB02	Existing Parking Directional	11
EB01	Existing Vehicular Directional	67
<b>SUB-TOTAL</b>		<b>82</b>

# Analysis

## Existing SLP

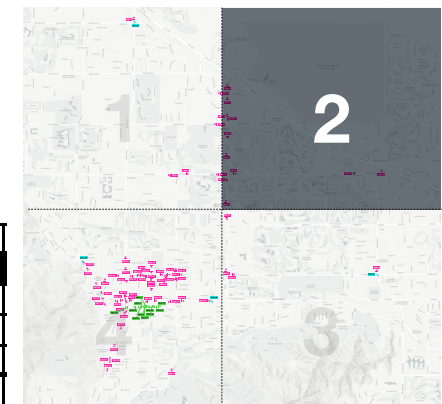
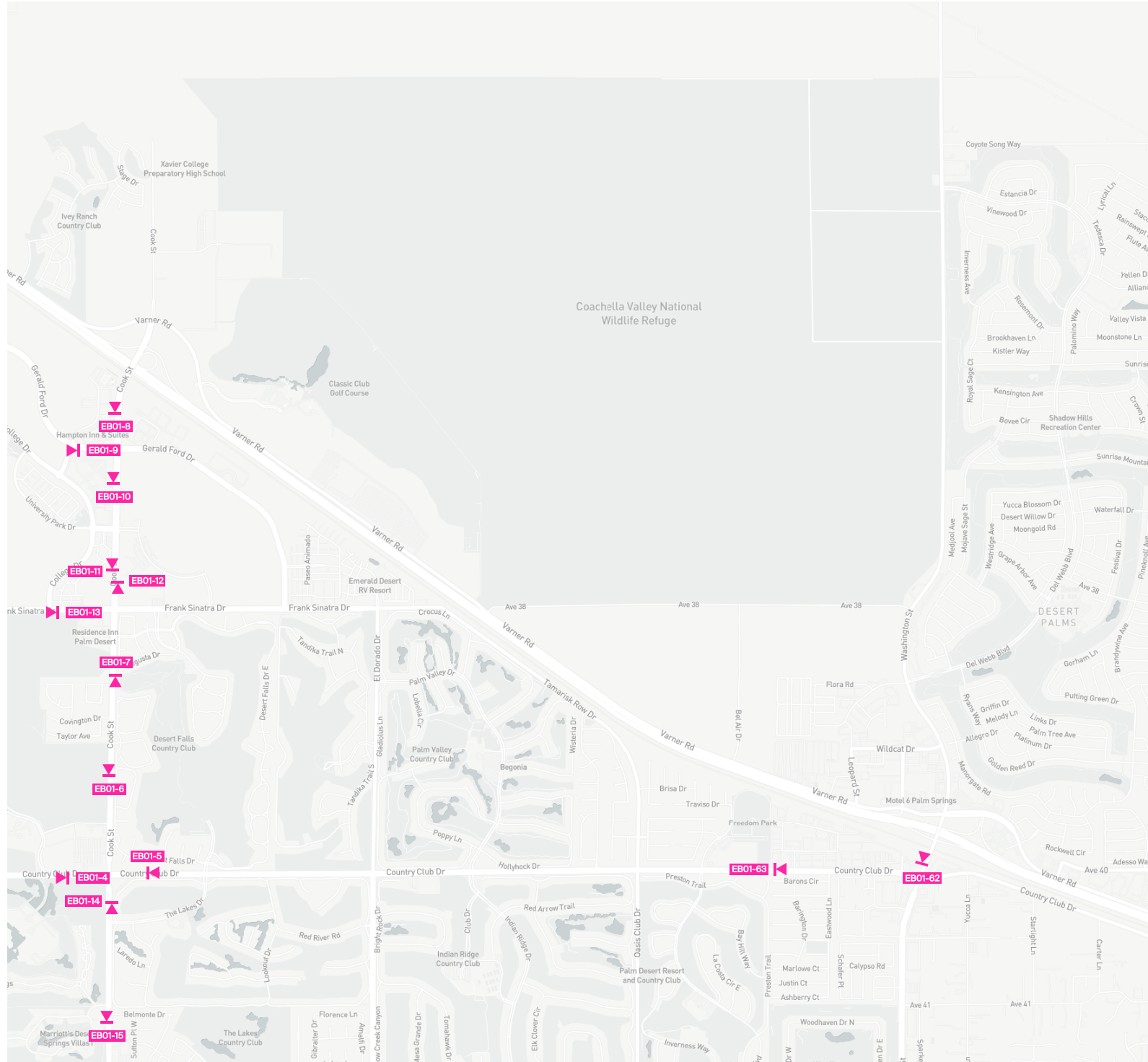

Type	Description	Qty.
<b>Citywide Wayfinding</b>		
EA01	Existing Monument Sign	4
EB02	Existing Parking Directional	11
EB01	Existing Vehicular Directional	67
<b>SUB-TOTAL</b>		<b>82</b>

# Analysis

## Existing SLP

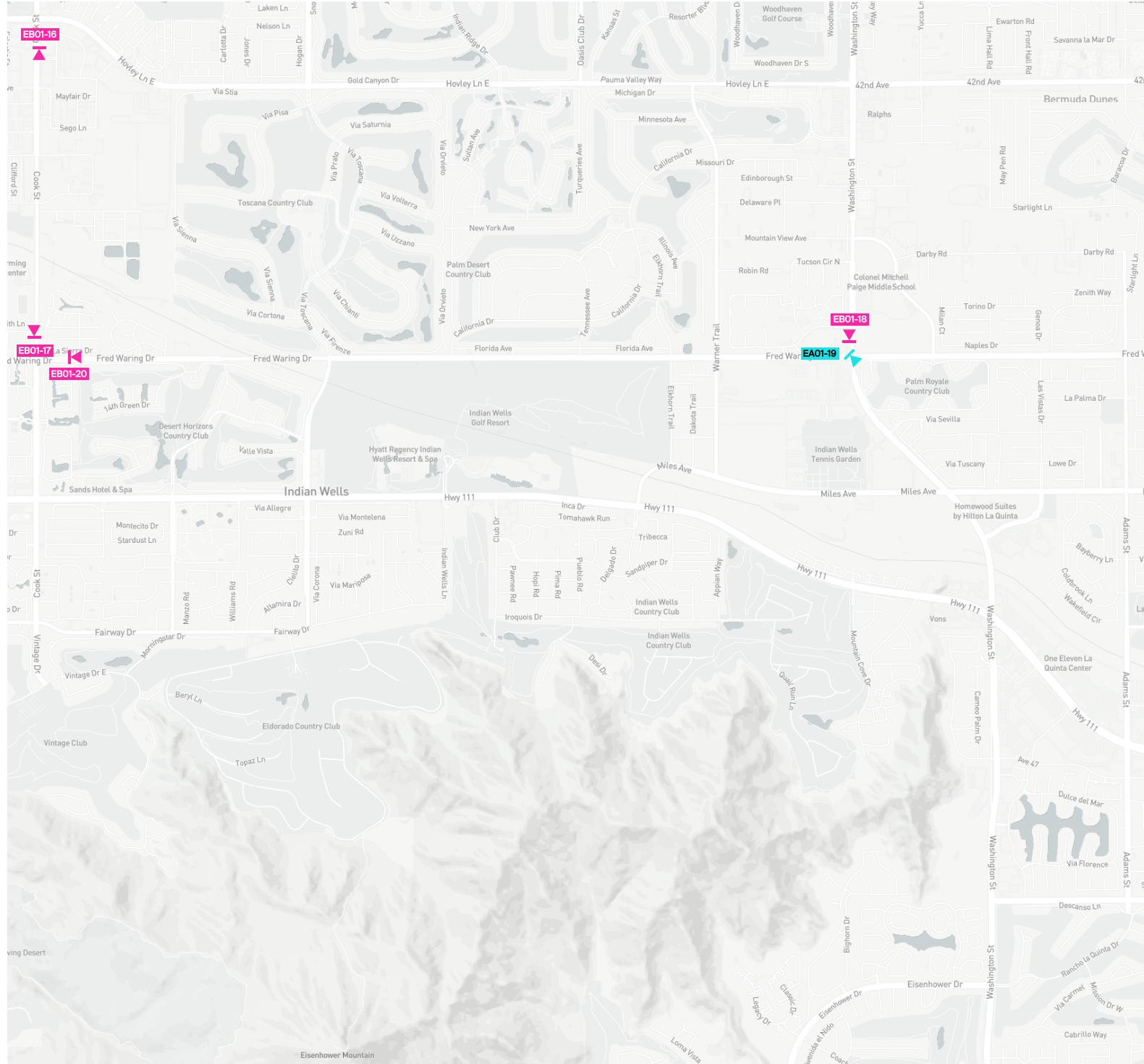

Type	Description	Qty.
<b>Citywide Wayfinding</b>		
EA01	Existing Monument Sign	4
EB02	Existing Parking Directional	11
EB01	Existing Vehicular Directional	67
<b>SUB-TOTAL</b>		<b>82</b>

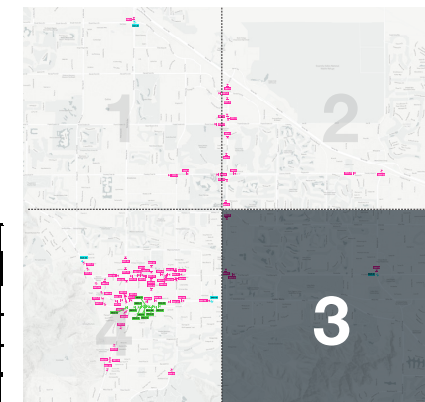

# Analysis

## Existing SLP

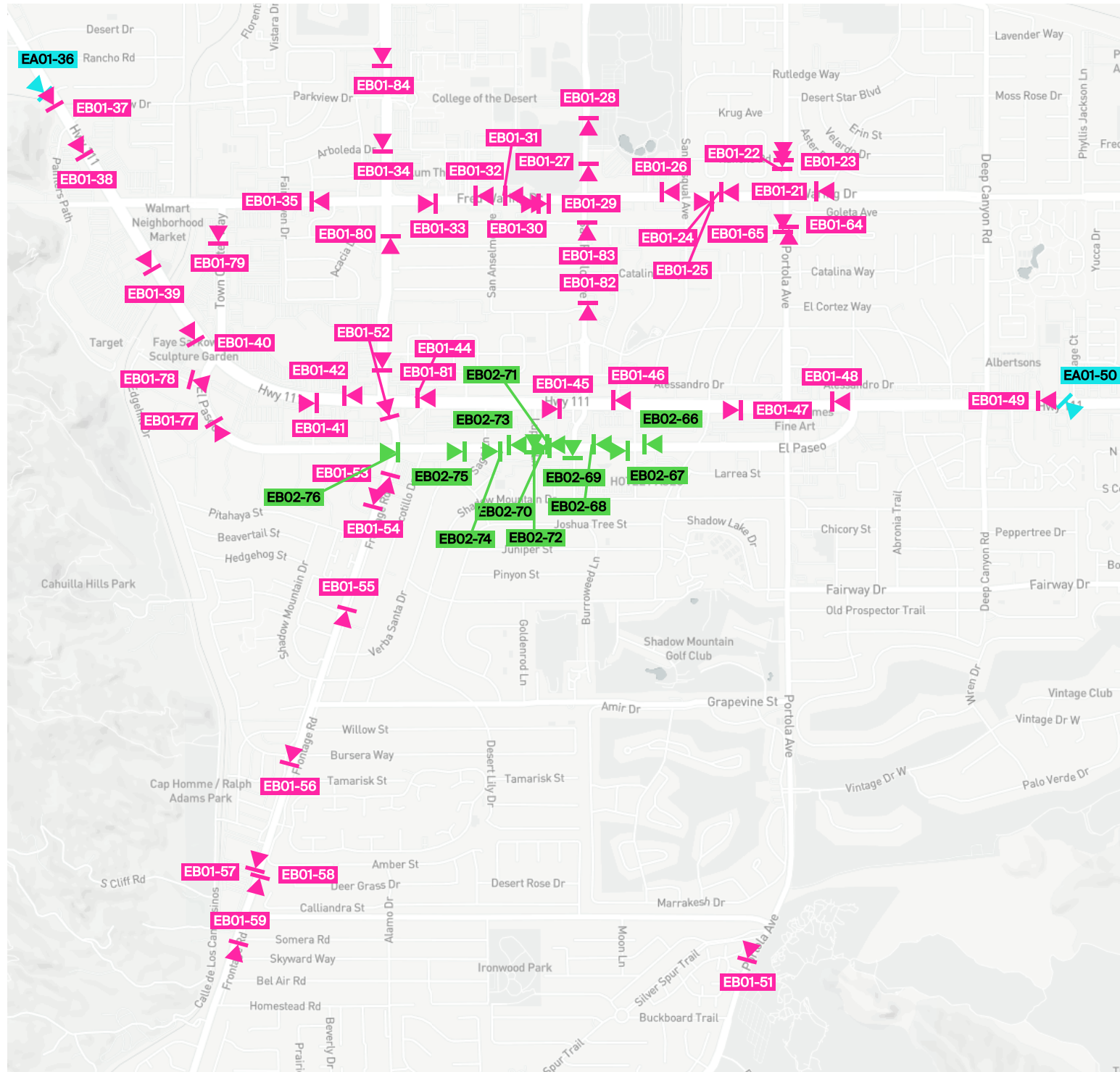

Type	Description	Qty.
<b>Citywide Wayfinding</b>		
EA01	Existing Monument Sign	4
EB02	Existing Parking Directional	11
EB01	Existing Vehicular Directional	67
<b>SUB-TOTAL</b>		<b>82</b>

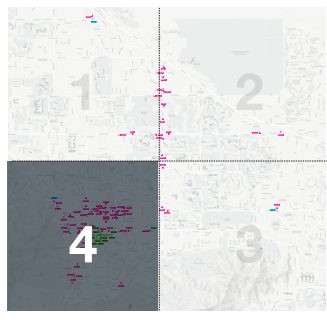

## S.W.O.T. Analysis



Following our analysis and survey findings, we crafted a S.W.O.T. report.

### Strengths

- Consistent, branded signage.
- Signs are helpful.

### Weaknesses

- Messaging is inconsistent.
- Too many signs in some areas.
- Entry monuments are inconsistent.
- Lack of pedestrian signage in walkable areas.
- Existing signage blends in with environment.
- Existing signage not visible at night.

### Opportunities

- Include new and existing destinations.
- Develop colorful branded signage that will appeal to visitors, residents and businesses.
- Use technology to enhance the wayfinding experience.

### Threats

- Some residents, visitors, businesses do not want to see signage change.
- Concerns why some businesses are included and not others.

## Recommendations

Based on the analysis, community outreach survey, and S.W.O.T. Report, the following signage and wayfinding approaches are recommended for the City of Palm Desert:

- Develop a colorful, branded signage and wayfinding system that will be visible day or night.
- Coordinate with City team to develop consistent messaging throughout sign system.
- Create a streamlined sign location plan, eliminating sign blight.
- Add pedestrian level signage in walkable areas.
- Add new destinations to wayfinding.
- Design a versatile digital sign suitable for various events, or incorporate QR codes into the proposed signage.





# City of Palm Desert Branding

# Branding



**PALM DESERT**  
C A L I F O R N I A

 **PALM DESERT**

## COLOR PALETTE



SUNSHINE YELLOW

cmyk: 0/31/91/0  
rgb: 253/183/49  
Hex: #fdb731  
PMS: 143 C



NATURAL BLACK

cmyk: 0/0/0/100  
rgb: 35/31/32  
Hex: #231f20  
PMS: Natural Black



ORANGE PEEL

cmyk: 0/47/98/0  
rgb: 248/153/29  
Hex: #f8991d  
PMS: 144 C



MIDNIGHT BLUE

cmyk: 100/73/10/48  
rgb: 15/68/120  
Hex: #0f4378  
PMS: 654 C



GRASS GREEN

cmyk: 86/15/100/2  
rgb: 0/152/73  
Hex: #009849  
PMS: 7741 C



MOUNTAIN RED

cmyk: 32/93/78/37  
rgb: 125/36/43  
Hex: #7d242b  
PMS: 1815 C



LEMON YELLOW

cmyk: 0/4/71/0  
rgb: 248/225/87  
Hex: #f8e157  
PMS: 113 C



SKY BLUE

cmyk: 93/60/13/1  
rgb: 0/101/158  
Hex: #00659e  
PMS: 647 C



GREEN GRAPES

cmyk: 54/0/100/0  
rgb: 130/195/65  
Hex: #82c341  
PMS: 369 C



CHILI PEPPER

cmyk: 12/100/96/3  
rgb: 209/32/43  
Hex: #d1202b  
PMS: 186 C



CLOUDY SKY

cmyk: 75/34/3/0  
rgb: 54/141/198  
Hex: #368dc6  
PMS: 7689 C



LIME GREEN

cmyk: 30/0/100/0  
rgb: 191/215/48  
Hex: #bfd730  
PMS: 381 C



STONE GRAY

cmyk: 33/18/13/37  
rgb: 123/129/132  
Hex: #7b8184  
PMS: 430 C

## PRIMARY FONT

Futura Book/*Book Oblique*

abcdefghijklmnopqrstuvwxy

ABCDEFGHIJKLMNPOQRSTUVWXYZ

Futura Light/*Light Oblique*

abcdefghijklmnopqrstuvwxy

ABCDEFGHIJKLMNPOQRSTUVWXYZ

## PRIMARY FONT FAMILY

Futura Condensed Light/*Condensed Light Oblique*

abcdefghijklmnopqrstuvwxy

ABCDEFGHIJKLMNPOQRSTUVWXYZ

Futura Condensed Medium/*Condensed Medium Oblique*

abcdefghijklmnopqrstuvwxy

ABCDEFGHIJKLMNPOQRSTUVWXYZ

Futura Condensed Bold/*Condensed Bold Oblique*

abcdefghijklmnopqrstuvwxy

ABCDEFGHIJKLMNPOQRSTUVWXYZ

Futura Condensed Extra Bold/  
*Condensed Extra Bold Oblique*

abcdefghijklmnopqrstuvwxy

ABCDEFGHIJKLMNPOQRSTUVWXYZ





# Signage Overview

# Signage

## Summary of Signs

A summary of signs provides an overview of the various categories of signs used within a wayfinding system, highlighting their purpose, design characteristics, and ideal placement.

This summary serves as a guide for selecting and implementing signage based on the specific needs of the environment.

### IDENTITY

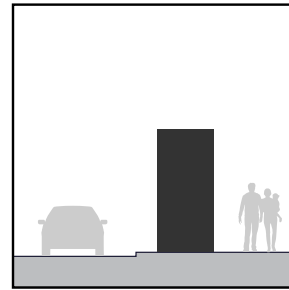

A01 GATEWAY MONUMENT

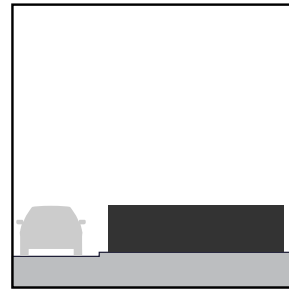

A02 GATEWAY MONUMENT

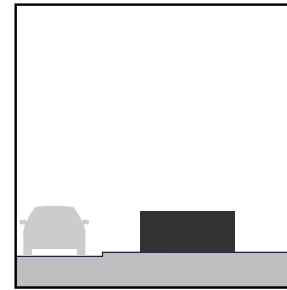

A03 GATEWAY MONUMENT

### DIRECTION

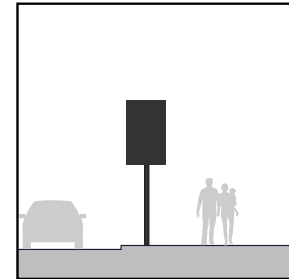

B01 VEHICLE DIRECTION LARGE

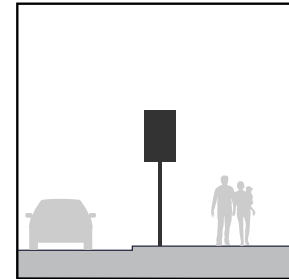

B02 VEHICLE DIRECTION MEDIUM

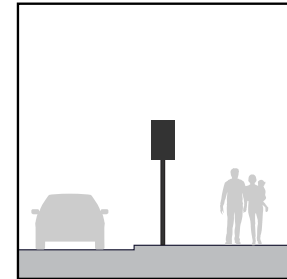

B03 VEHICLE DIRECTION SMALL

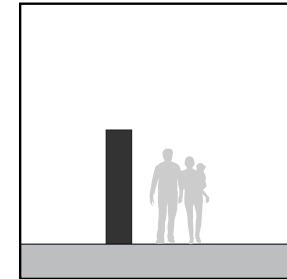

B04 PEDESTRIAN DIRECTION W/ MAP

### AMENITY

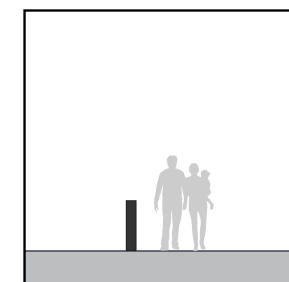

E01 ART TOTEM - EXISTING

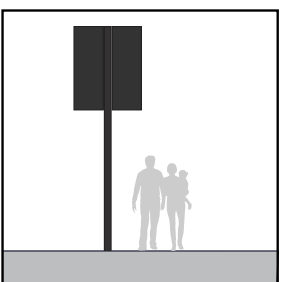

E02 BANNER

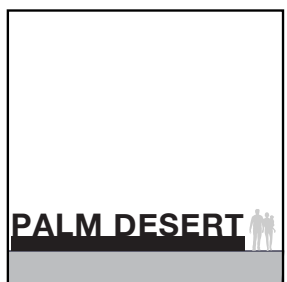

E03 PLACEMAKING

# Signage

## Concept Moodboard

The Palm Desert signage and wayfinding system blends the timeless elegance of the desert landscape with the city’s bold, modern energy. Drawing inspiration from the region’s natural sandstone formations, each monument incorporates textured stone finishes that evoke the surrounding mountains and arid terrain. These classic materials are juxtaposed with bright, vibrant panels in golden hues, reflecting the city’s radiant sun, contemporary design sensibility, and active lifestyle.

Typography, color, and form come together to create a cohesive visual language that is both highly functional and distinctly Palm Desert. From iconic gateway monuments to intuitive vehicle and pedestrian signage, the system elevates the experience of both residents and visitors by improving navigation while reinforcing civic pride.

More than a wayfinding program, this system is an expression of place—capturing the spirit of Palm Desert as a destination defined by natural beauty, cultural sophistication, and vibrant community life.



## Signage

### Family of Signs

The three sign types shown on this page represent the approved monument designs for Palm Desert. These monuments will be installed at three distinct locations designated by the City of Palm Desert.

Each sign features a dual-layered design: a front sandstone element sculpted to reflect the surrounding desert landscape, and a rear metal panel painted in alignment with the City’s branding. The metal panel will include a cut-out of the Palm Desert logo. Integrated between the two layers is a lighting feature that casts a soft glow along the sandstone edge—evoking the visual of a sunset behind the mountains.

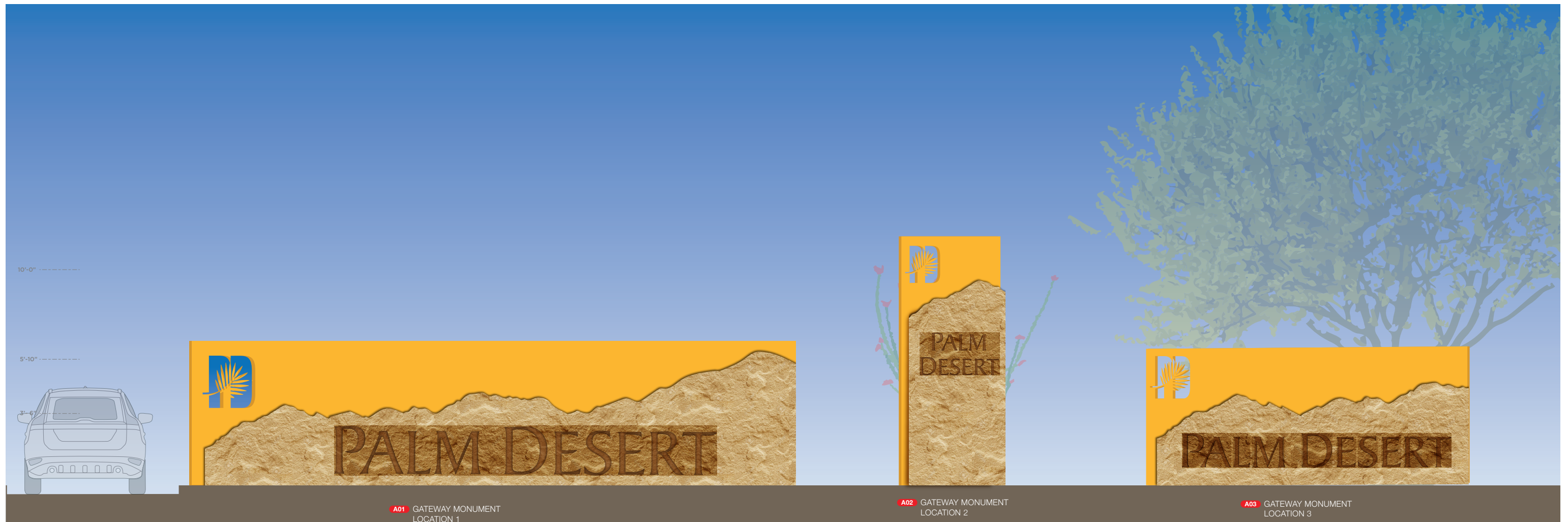

# Signage

## Family of Signs

The wayfinding signage is designed to align with the approved monument aesthetic, incorporating consistent City-branded colors and a mountain graphic on the reverse side for added visual interest. Messaging will be displayed at a height of six inches to ensure legibility on high-speed roadways, and all signage will feature the official City logo.

The pedestrian directory sign will share the same visual language as the vehicular signs, maintaining a cohesive look and feel across the system. It will include a map and corresponding directory to support easy navigation for pedestrians.

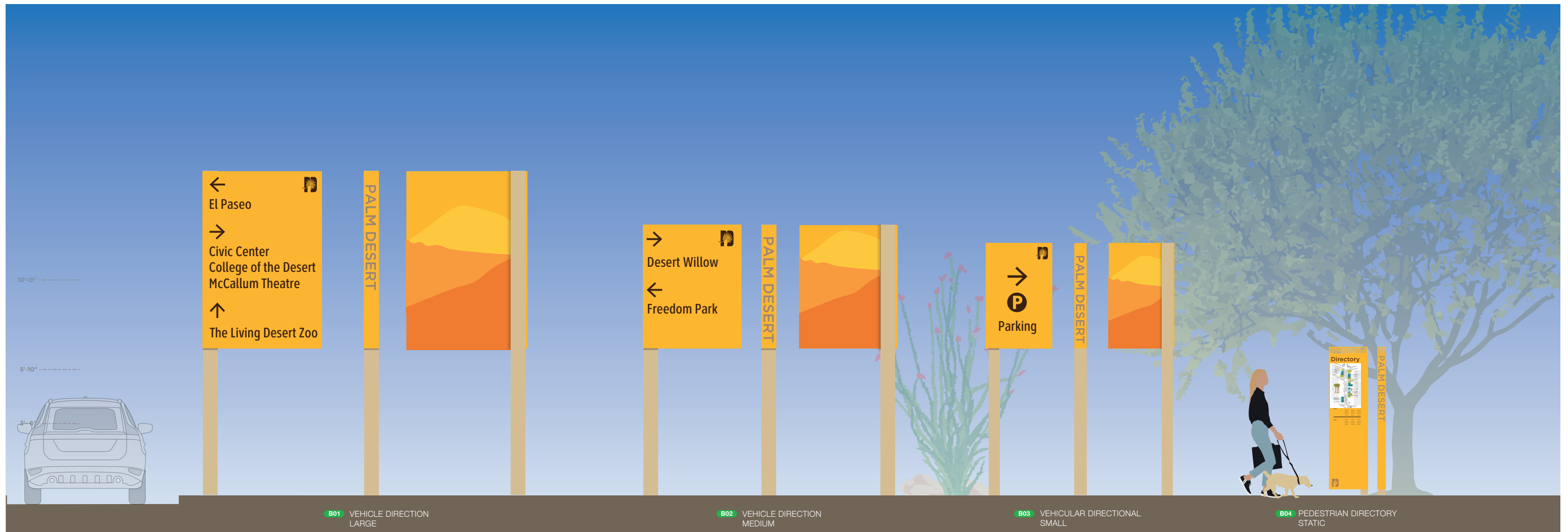

# Signage Renderings

The monument and wayfinding signage has been integrated into contextual renderings to illustrate its placement at specific locations and how it will interact with the surrounding environment. These renderings include both day and night views, ensuring the design maintains appropriate height, scale, and clear legibility of the city name and logo under varying lighting conditions.



# Signage Renderings

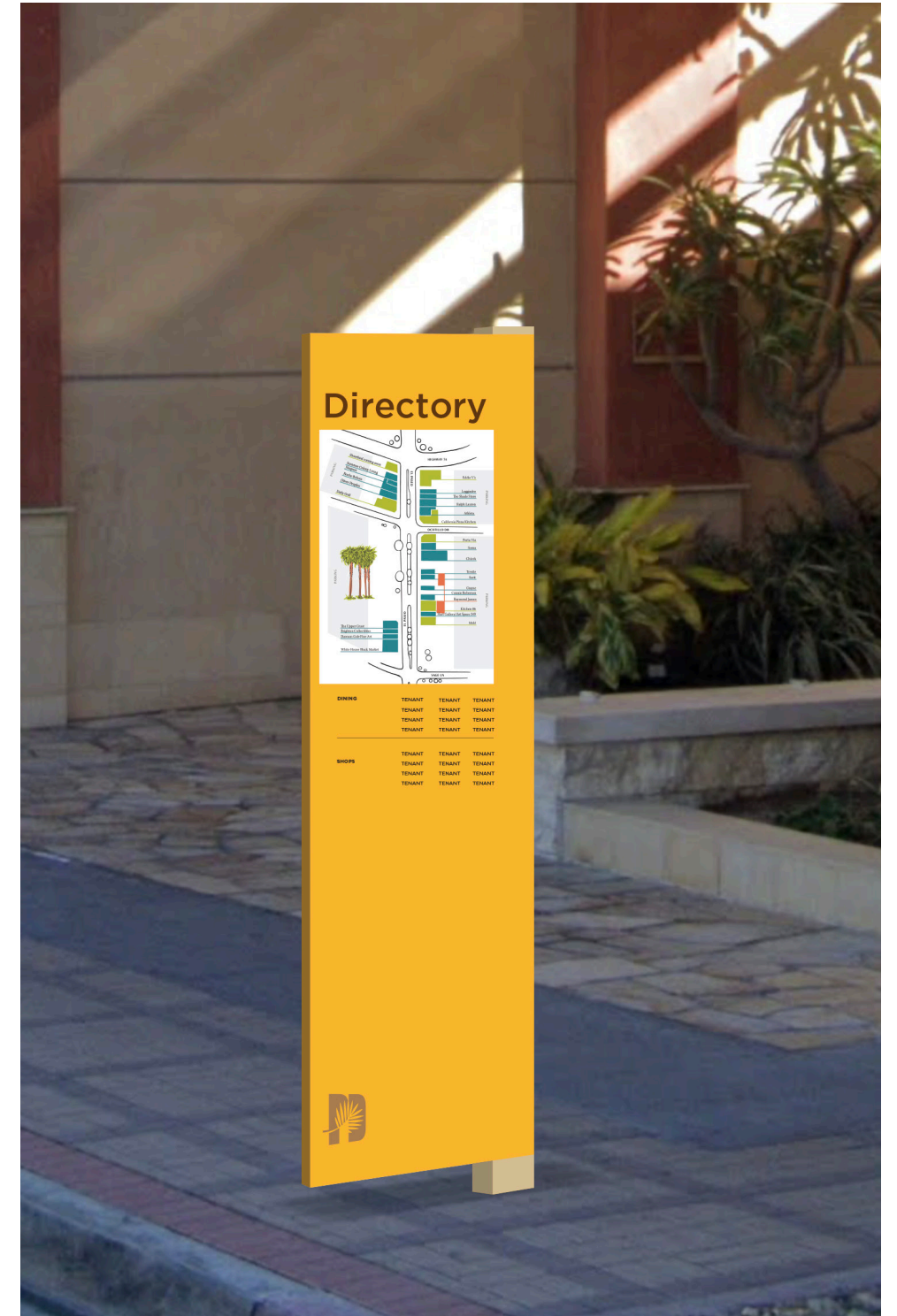
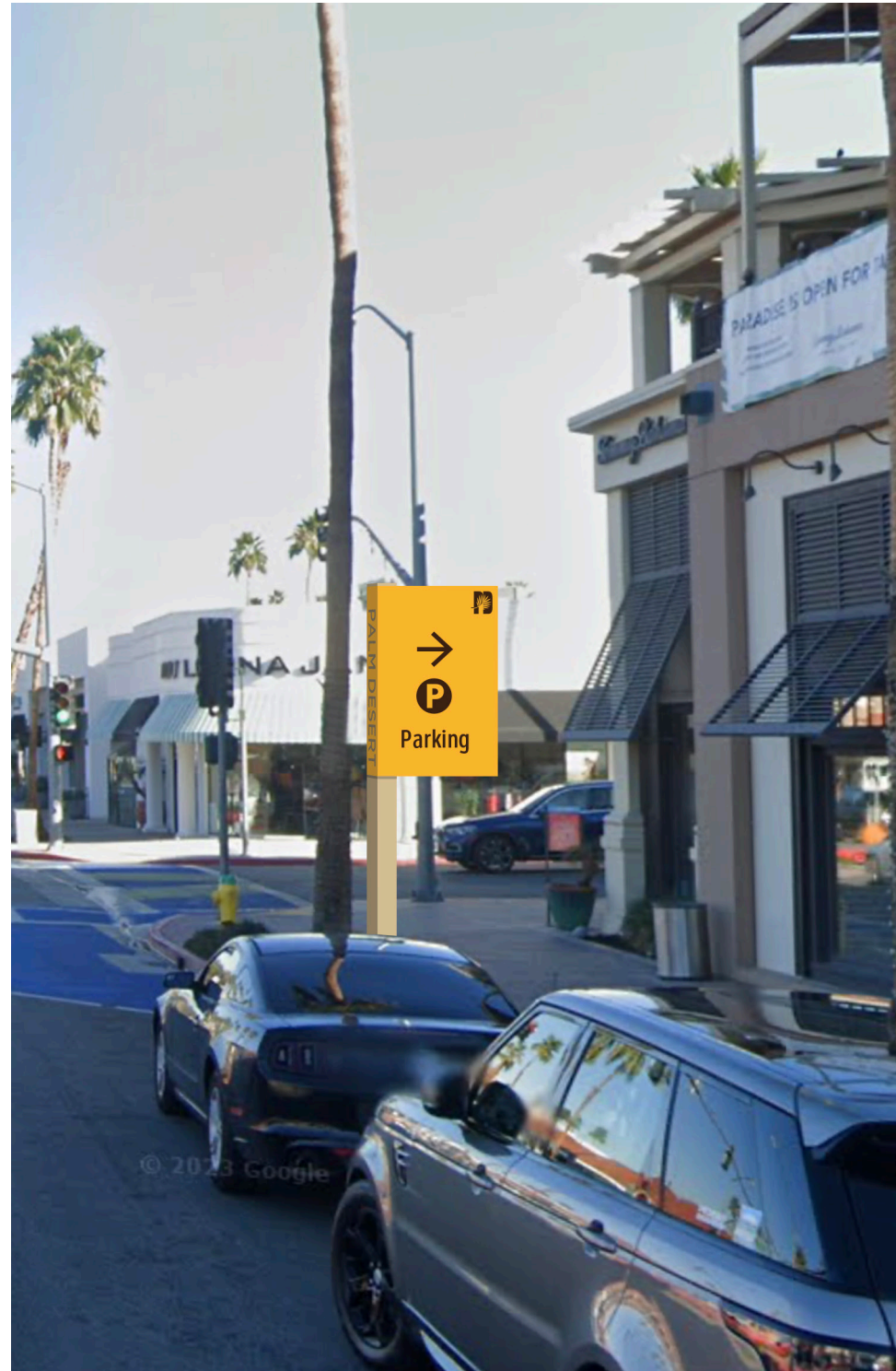

4

Sign Details

# Color, Materials, Type, & Symbols

## Color

Color is an essential and effective component of the signage program. Its ability to communicate transcends language, promotes clarity, and helps to identify important information

This signage colors palette is approved for use at all City of Palm Desert facilities and shall never be substituted to ensure consistency of the signage system.

Signage not regulated by the City of Palm Desert will use other colors as required by their governing codes.

### PAINTS



**P1**  
MP-26406  
PASTEL ORANGE  
PANTONE 143C  
SUNSHINE YELLOW



**P2**  
MP-11705  
CHOCOLATE THUNDER  
CMYK: 40,70,100,50



**P3**  
MP-10211  
CITRUS YELLOW  
CMYK: 0,21,85,0



**P4**  
MP-853  
PLASTIC PUMPKIN  
CMYK: 2,63,91,0



**P5**  
MP-1224  
ORANGE SUPREME  
CMYK: 0,47,85,0



**P6**  
MP-21250  
MONETA GOLD  
CMYK: 5,15,38,13



**P7**  
MP-46534  
COBRE COPPER  
CMYK: 30,50,75,10

# Color, Materials, Type, & Symbols

## Materials

The signage system features a combination of durable and high-quality materials chosen for their longevity, sustainability, and compatibility with Palm Desert’s environment.

The use of metal panels provides a modern, resilient solution capable of withstanding the region’s intense heat and sun exposure, ensuring long-term performance with minimal maintenance.

Stone offers lasting durability and low maintenance—it resists fading, weathering, and damage from wind and sand—making it an ideal material for long-term use

All materials have been carefully reviewed and approved by the City of Palm Desert, and any variation from these standards should be coordinated with City management to maintain design integrity and consistency.

### MATERIALS



ALUMINUM

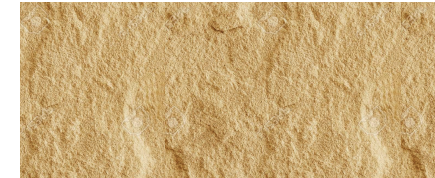

SANDSTONE

## Color, Materials, Type, & Symbols

### Type

Visual messages must communicate quickly and profoundly. Typography supports effective wayfinding with the consistent use of legible fonts, suitable letter and word spacing, appropriate size, and rules of usage.

CLEARVIEW ADA CONDENSED

A B C D E F G H I J K L M N O P Q R S T U V W X Y Z  
a b c d e f g h i j k l m n o p q r s t u v w x y z  
0 1 2 3 4 5 6 7 8 9

GOTHAM BOLD

A B C D E F G H I J K L M N O P Q R S T U V W X Y Z  
a b c d e f g h i j k l m n o p q r s t u v w x y z  
0 1 2 3 4 5 6 7 8 9

## Color, Materials, Type, & Symbols

### Symbols

A pictogram is a symbol that indicates, signifies, or represents an idea, object, space, activity, or relationship without the use of words. Many of our pictograms are universally understood and aid in wayfinding because of the clarity of their design and recognizable meaning, thereby eliminating the need for multiple language translations. When feasible, pictograms may be used with an accompanying word description for maximum message comprehension. These pictograms are the only approved symbols for use at all City of Palm Desert facilities and shall never be altered.

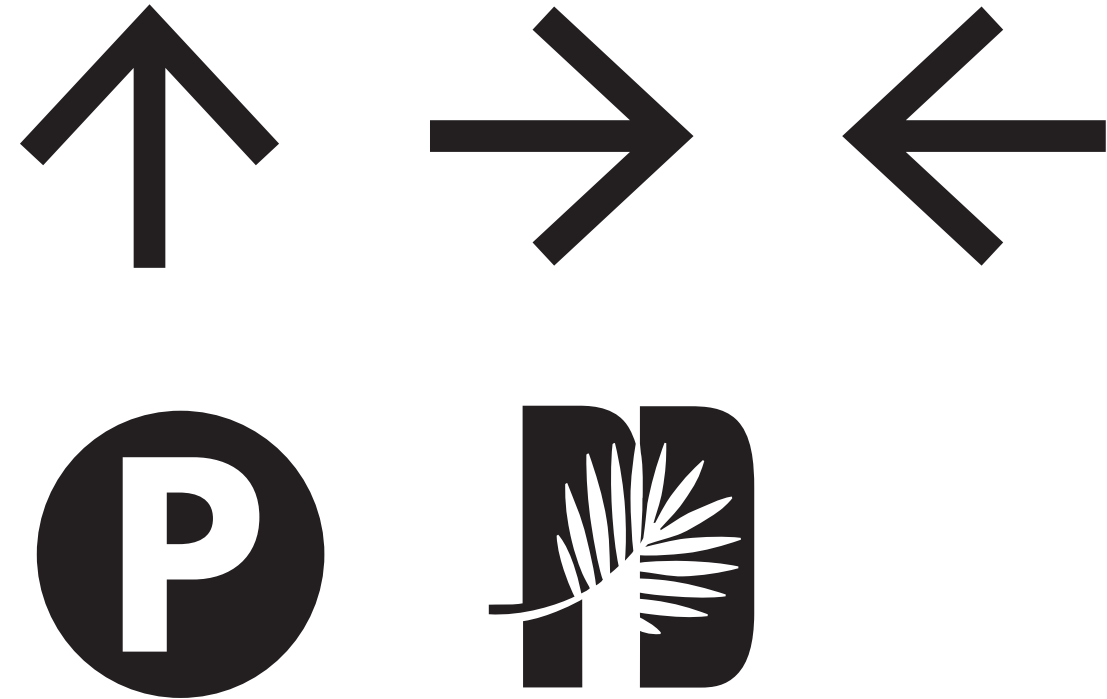

# PALM DESERT

# Detail Drawings

## A01 - Gateway Monument 1



**4** CONTEXT ELEVATION  
Scale: 1/8" = 1'-0"

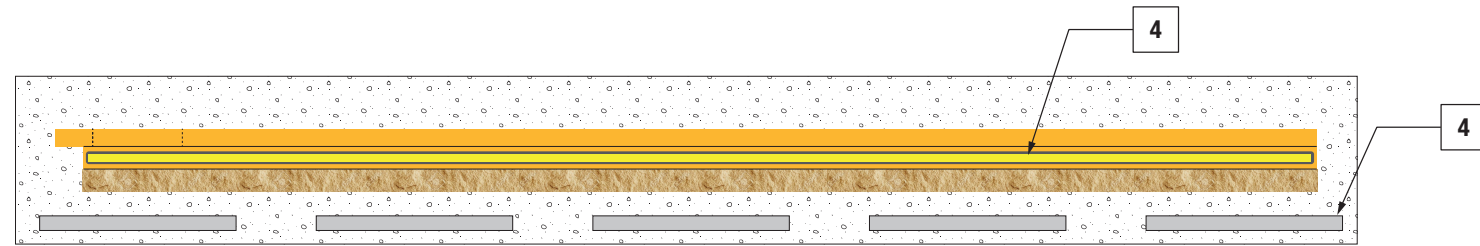

**3** PLAN VIEW  
Scale: 1/4" = 1'-0"

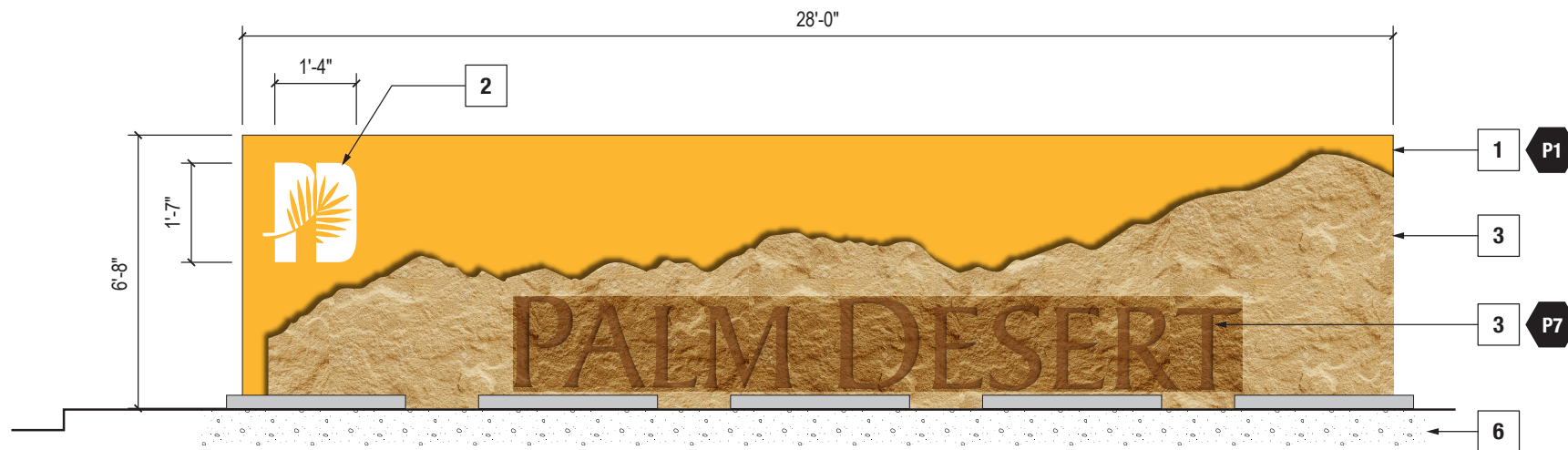

**1** FRONT ELEVATION  
Scale: 1/4" = 1'-0"

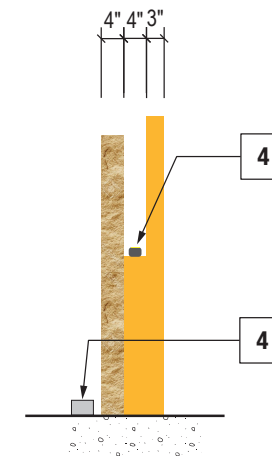

**2** SIDE ELEVATION  
Scale: 1/4" = 1'-0"

### NOTES – SIGN TYPE A01

1. BACK PANEL: 3" deep fabricated aluminum sign cabinet with structural framing. No visible seams between panels. Aluminum panels to be welded, grinded, filled and sanded smooth prior to painting. Provide UV protective clear coat.
2. CITY LOGO: City logo to be routed out and fabricated with returns.
3. STONE SLAB: Min. 3" thick solid shaped sandstone with carved graphics. Graphics to have paint fill.
4. ILLUMINATIONS: Halo illumination behind stone. Up-lighting for front of sign.
5. ATTACHMENT: Monument to be bolted to concrete footing. Sign fabricator to engineering required concrete footing and final installation method.
6. CONCRETE FOOTING: Sign fabricator is responsible for the engineering of the concrete footing.
7. POWER: Sign contractor to coordinate electrical conduit and power access with general contractor; components' requirements per manufacturer's specifications; provide accessible on/off switch.

### GENERAL NOTES

- A. MEASUREMENTS & LOCATIONS: Sign Contractor to field verify all measurements and conditions, and determine final sign locations with owner prior to creating shop drawings and/or digging the footing.
- B. DESIGN INTENT: Drawings display design intent. Sign Contractor to verify efficacy of fabrication and installation methods proposed with designer prior to creating shop drawings.

# Detail Drawings

## A02 - Gateway Monument 2

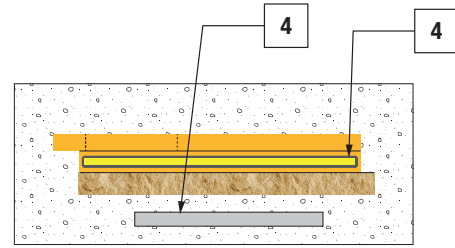

**4 PLAN VIEW**  
Scale: 1/4" = 1'-0"

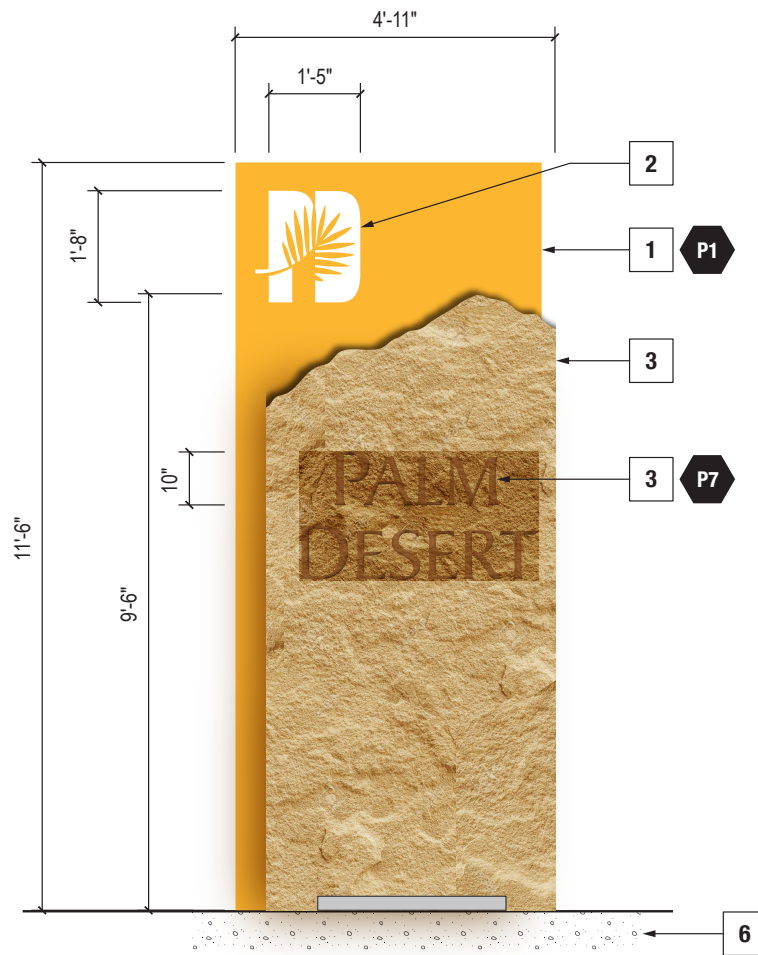

**1 FRONT ELEVATION**  
Scale: 3/8" = 1'-0"

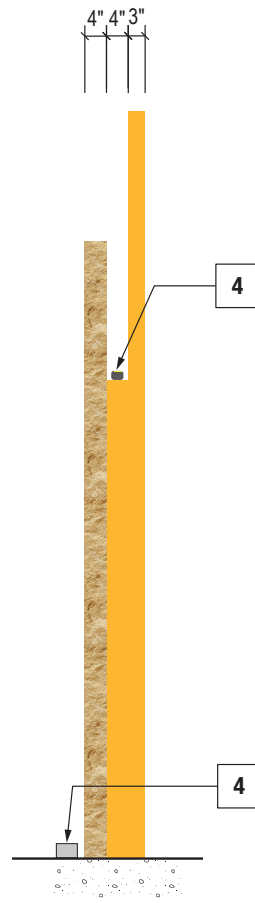

**2 SIDE ELEVATION**  
Scale: 1/4" = 1'-0"

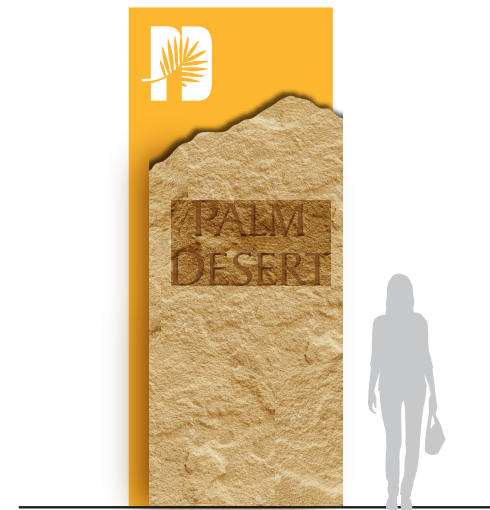

**3 CONTEXT ELEVATION**  
Scale: 1/4" = 1'-0"

### NOTES – SIGN TYPE A02

1. BACK PANEL: 3" deep fabricated aluminum sign cabinet with structural framing. No visible seams between panels. Aluminum panels to be welded, grinded, filled and sanded smooth prior to painting. Provide UV protective clear coat.
2. CITY LOGO: City logo to be routed out and fabricated with returns.
3. STONE SLAB: Min. 3" thick solid shaped sandstone with carved graphics. Graphics to have paint fill.
4. ILLUMINATIONS: Halo illumination behind stone. Up-lighting for front of sign.
5. ATTACHMENT: Monument to be bolted to concrete footing. Sign fabricator to engineering required concrete footing and final installation method.
6. CONCRETE FOOTING: Sign fabricator is responsible for the engineering of the concrete footing.
7. POWER: Sign contractor to coordinate electrical conduit and power access with general contractor; components' requirements per manufacturer's specifications; provide accessible on/off switch.

### GENERAL NOTES

- A. MEASUREMENTS & LOCATIONS: Sign Contractor to field verify all measurements and conditions, and determine final sign locations with owner and RJM prior to creating shop drawings and/or digging the footing.
- B. DESIGN INTENT: Drawings display design intent. Sign Contractor to verify efficacy of fabrication and installation methods proposed with designer prior to creating shop drawings.

# Detail Drawings

## A03 - Gateway Monument 3

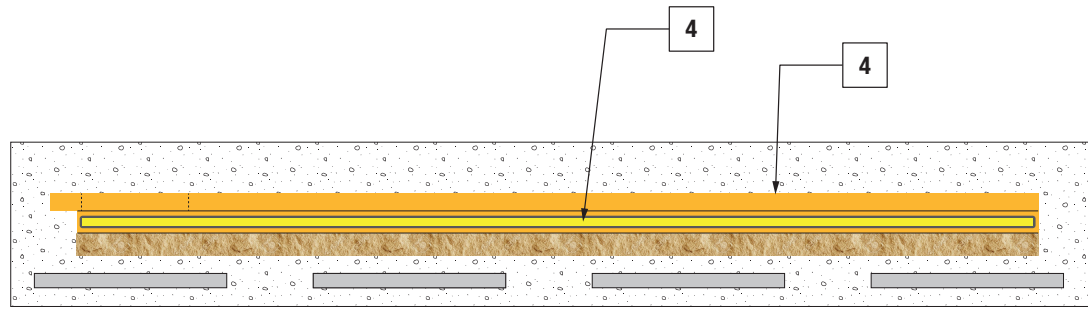

**3 PLAN VIEW**  
Scale: 3/8" = 1'-0"

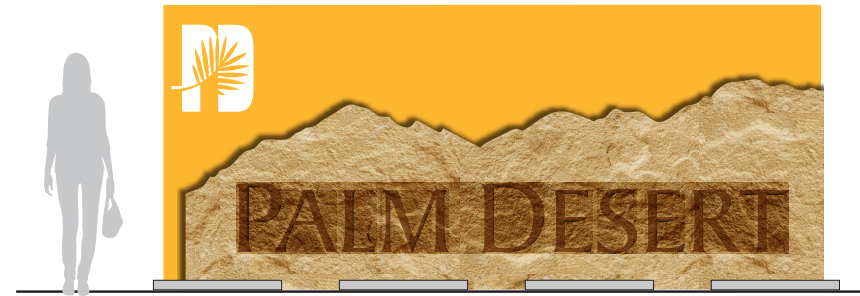

**4 CONTEXT ELEVATION**  
Scale: 1/4" = 1'-0"

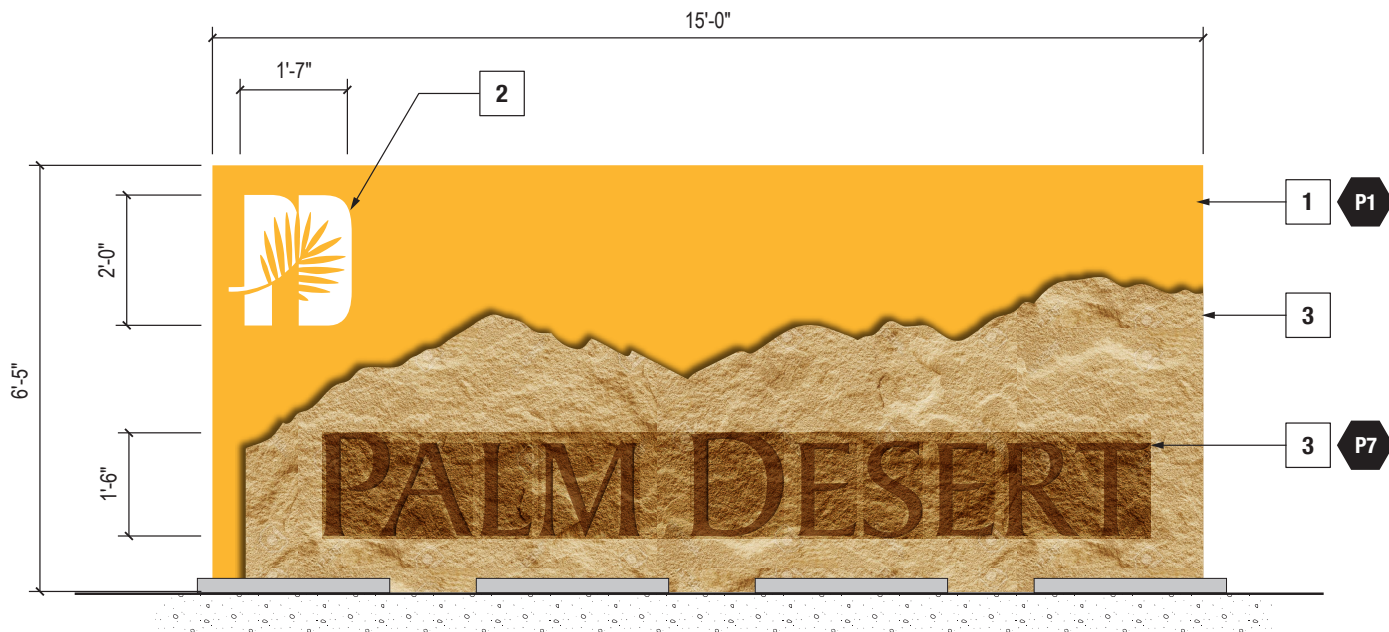

**1 FRONT ELEVATION**  
Scale: 3/8" = 1'-0"

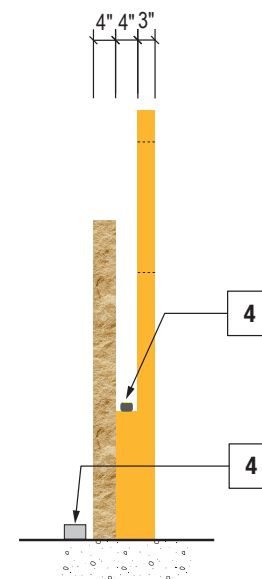

**2 SIDE ELEVATION**  
Scale: 3/8" = 1'-0"

### NOTES – SIGN TYPE A03

1. BACK PANEL: 3" deep fabricated aluminum sign cabinet with structural framing. No visible seams between panels. Aluminum panels to be welded, grinded, filled and sanded smooth prior to painting. Provide UV protective clear coat.
2. CITY LOGO: City logo to be routed out and fabricated with returns.
3. STONE SLAB: Min. 3" thick solid shaped sandstone with carved graphics. Graphics to have paint fill.
4. ILLUMINATIONS: Halo illumination behind stone. Up-lighting for front of sign.
5. ATTACHMENT: Monument to be bolted to concrete footing. Sign fabricator to engineering required concrete footing and final installation method.
6. CONCRETE FOOTING: Sign fabricator is responsible for the engineering of the concrete footing.
7. POWER: Sign contractor to coordinate electrical conduit and power access with general contractor; components' requirements per manufacturer's specifications; provide accessible on/off switch.

### GENERAL NOTES

- A. MEASUREMENTS & LOCATIONS: Sign Contractor to field verify all measurements and conditions, and determine final sign locations with owner and RJM prior to creating shop drawings and/or digging the footing.
- B. DESIGN INTENT: Drawings display design intent. Sign Contractor to verify efficacy of fabrication and installation methods proposed with designer prior to creating shop drawings.

# Detail Drawings

## B01 - Vehicle Direction Large

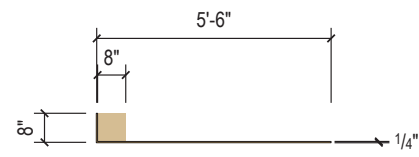

**4 PLAN VIEW**  
Scale: 1/4" = 1'-0"

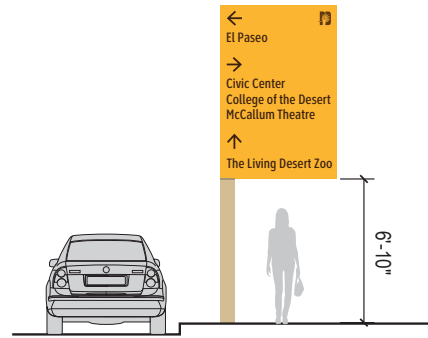

**5 CONTEXT ELEVATION**  
Scale: 1/8" = 1'-0"

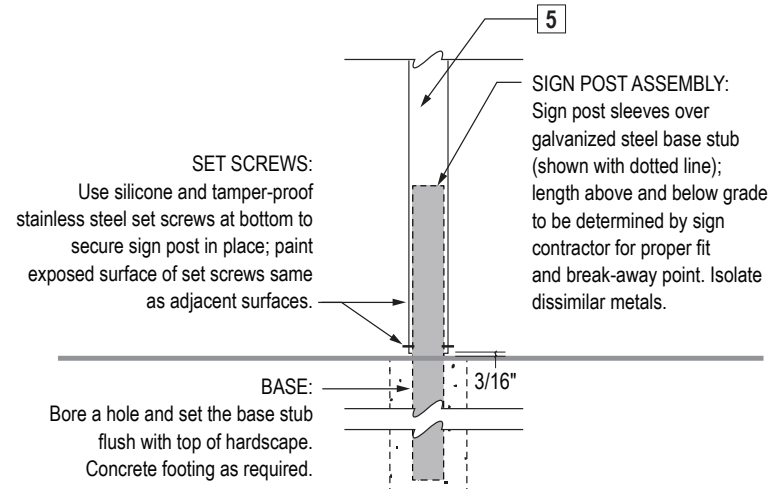

**6 POST DETAIL**  
Scale: N.T.S.

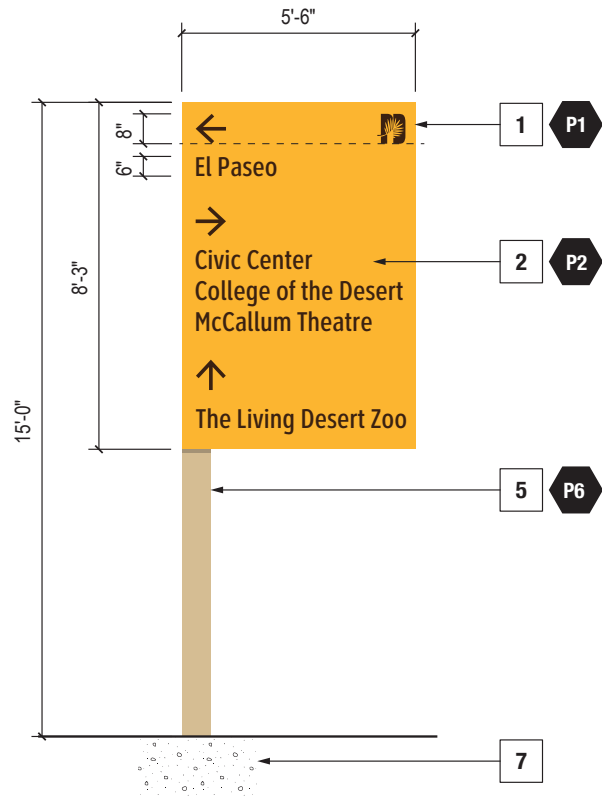

**1 FRONT ELEVATION - B01-48(CLONED)**  
Scale: 1/4" = 1'-0"

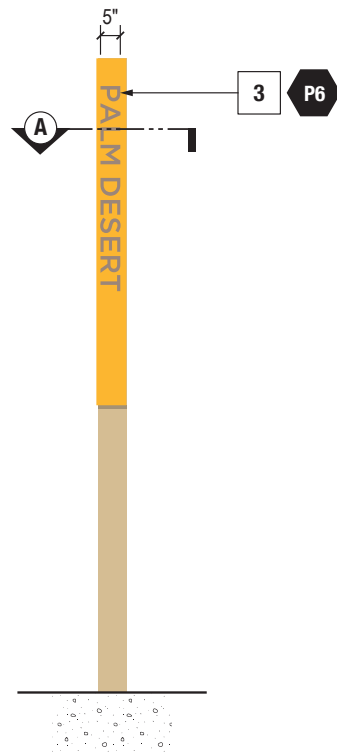

**2 SIDE ELEVATION**  
Scale: 1/4" = 1'-0"

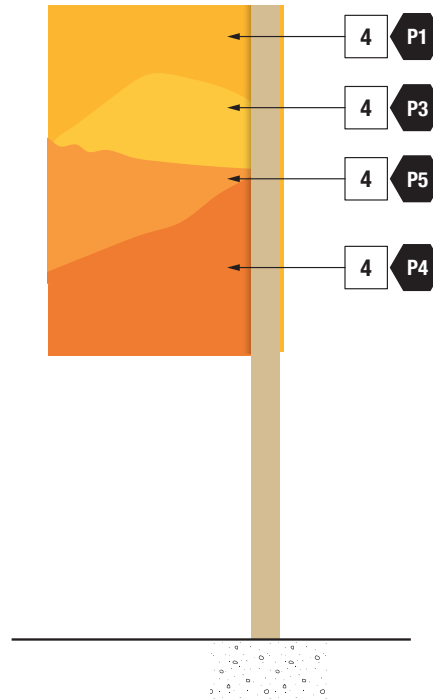

**3 REAR ELEVATION**  
Scale: 1/4" = 1'-0"

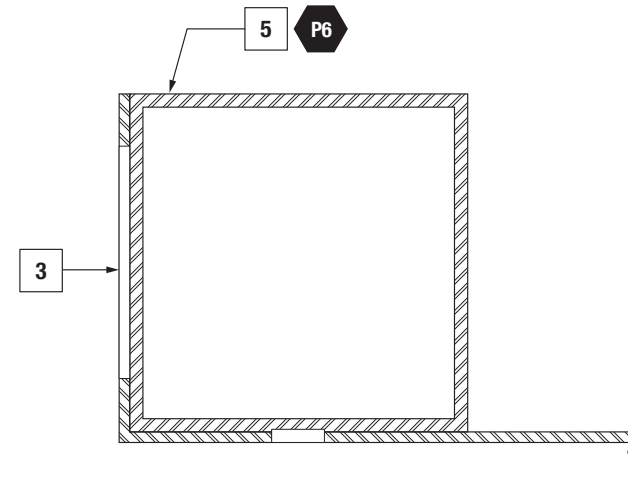

**5 SECTION A**  
Scale: 3" = 1'-0"

### NOTES - SIGN TYPE B01

1. MESSAGE PANEL: Minimum 1/4" thick flat aluminum panel with paint finish. Provide UV protective clear coat. Sign panel to wrap around sign post. Message panel to be plug welded to post. Grind, fill and sand smooth all welds prior to painting.
2. SIGN MESSAGE: Surface printed graphics.
3. SIDE PANEL MESSAGE: Reversed cut out letters. Sign post color to show thru.
4. REAR PANEL GRAPHICS: Surface printed graphics on backside of sign panel
5. SIGN POST: 8" Aluminum square post with top capped and paint finish.
6. ATTACHMENT: Steel post to be directly embeded into concrete footing, Sign post to sleeve onto embeded post and secured with tamper proof stainless steel mechanical fasteners.
7. CONCRETE FOOTING: Sign fabricator is responsible for the engineering of the concrete footing.

### GENERAL NOTES

- A. MEASUREMENTS & LOCATIONS: Sign Contractor to field verify all measurements and conditions, and determine final sign locations with owner and RJM prior to creating shop drawings and/or digging the footing.
- B. DESIGN INTENT: Drawings display design intent. Sign Contractor to verify efficacy of fabrication and installation methods proposed with designer prior to creating shop drawings.

# Detail Drawings

## B02 - Vehicle Direction Medium

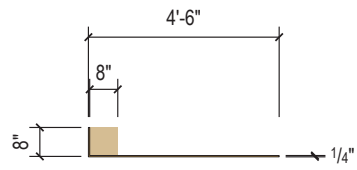

**4 PLAN VIEW**  
Scale: 1/4" = 1'-0"

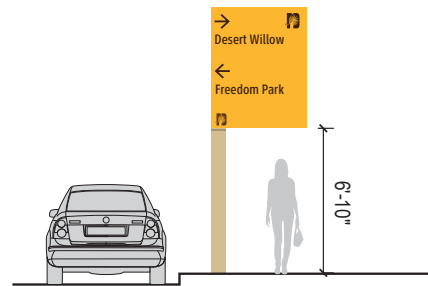

**5 CONTEXT ELEVATION**  
Scale: 1/8" = 1'-0"

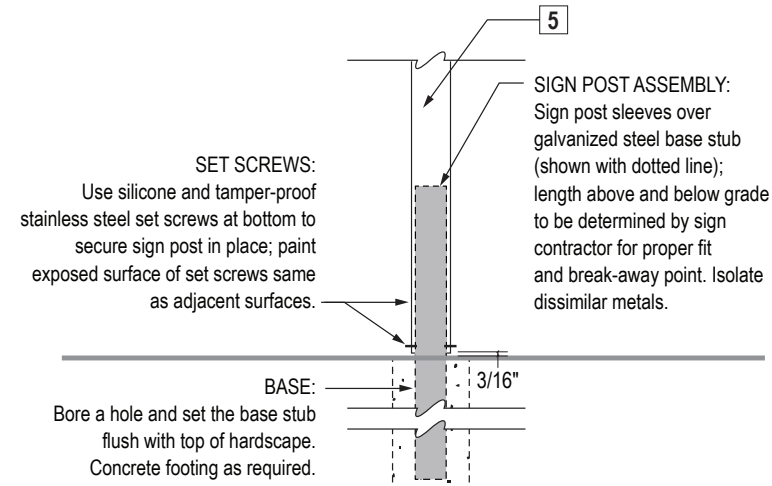

**6 POST DETAIL**  
Scale: N.T.S.

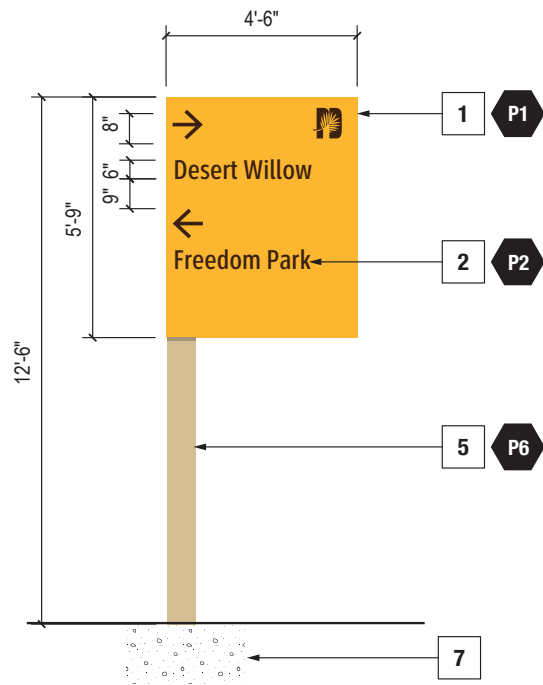

**1 FRONT ELEVATION - B02-6(CLONED)**  
Scale: 1/4" = 1'-0"

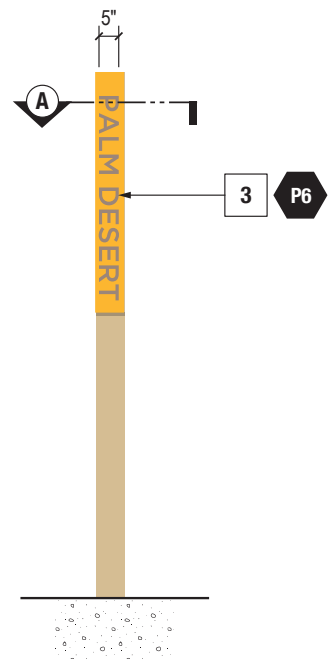

**2 SIDE ELEVATION**  
Scale: 1/4" = 1'-0"

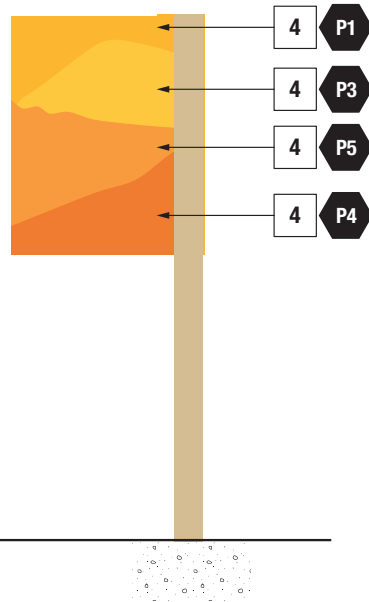

**3 REAR ELEVATION**  
Scale: 1/4" = 1'-0"

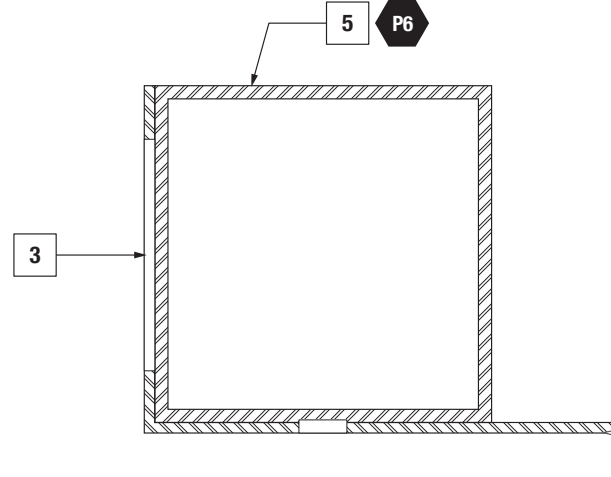

**A SECTION A**  
Scale: 3" = 1'-0"

### NOTES - SIGN TYPE B02

1. MESSAGE PANEL: Minimum 1/4" thick flat aluminum panel with paint finish. Provide UV protective clear coat. Sign panel to wrap around sign post. Message panel to be plug welded to post. Grind, fill and sand smooth all welds prior to painting.
2. SIGN MESSAGE: Surface printed graphics.
3. SIDE PANEL MESSAGE: Reversed cut out letters. Sign post color to show thru.
4. REAR PANEL GRAPHICS: Surface printed graphics on backside of sign panel
5. SIGN POST: 8" Aluminum square post with top capped and paint finish.
6. ATTACHMENT: Steel post to be directly embeded into concrete footing, Sign post to sleeve onto embeded post and secured with tamper proof stainless steel mechanical fasteners.
7. CONCRETE FOOTING: Sign fabricator is responsible for the engineering of the concrete footing.

### GENERAL NOTES

- A. MEASUREMENTS & LOCATIONS: Sign Contractor to field verify all measurements and conditions, and determine final sign locations with owner and RJM prior to creating shop drawings and/or digging the footing.
- B. DESIGN INTENT: Drawings display design intent. Sign Contractor to verify efficacy of fabrication and installation methods proposed with designer prior to creating shop drawings.

# Detail Drawings

## B03 - Vehicle Direction Small

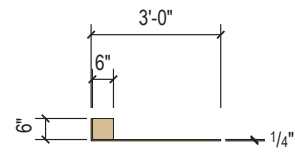

**4 PLAN VIEW**  
Scale: 1/4" = 1'-0"

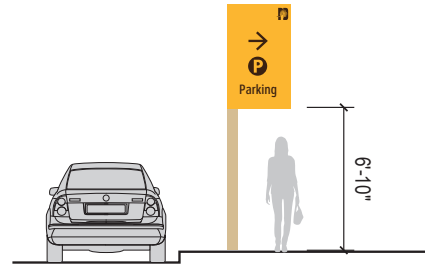

**5 CONTEXT ELEVATION**  
Scale: 1/8" = 1'-0"

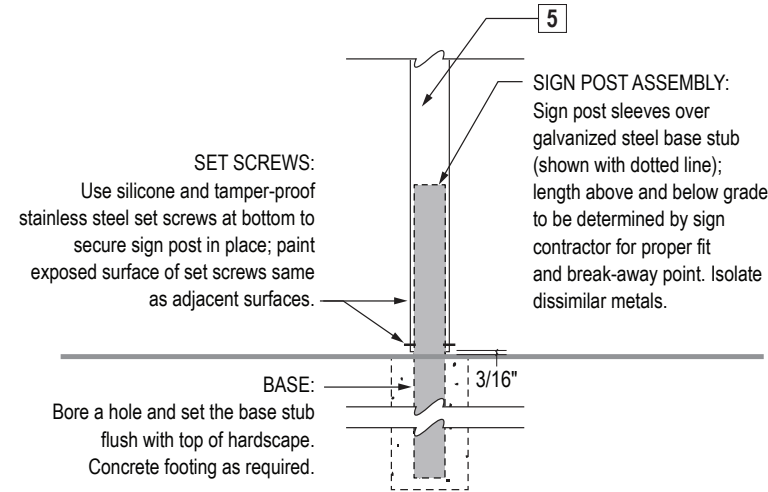

**6 POST DETAIL**  
Scale: N.T.S.

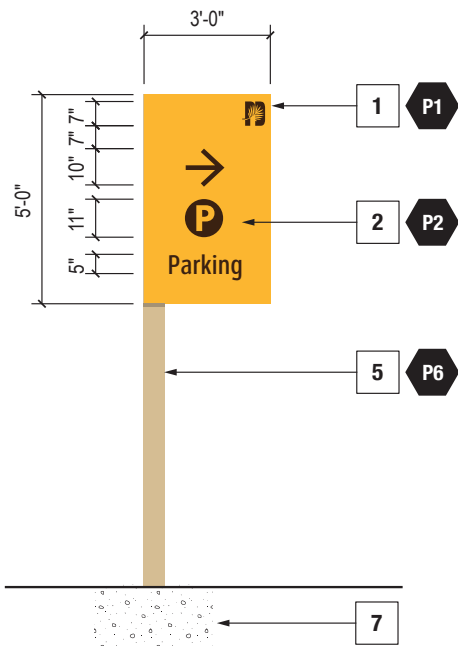

**1 FRONT ELEVATION**  
Scale: 1/4" = 1'-0"

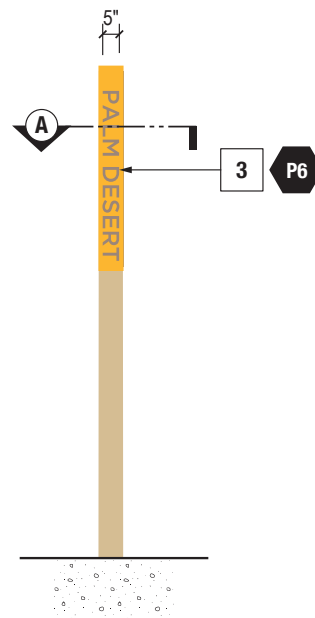

**2 SIDE ELEVATION**  
Scale: 1/4" = 1'-0"

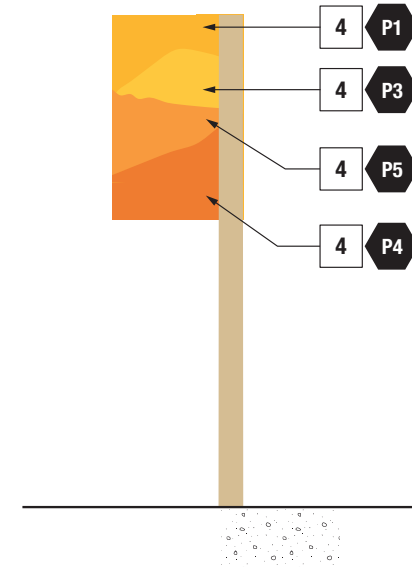

**3 REAR ELEVATION**  
Scale: 1/4" = 1'-0"

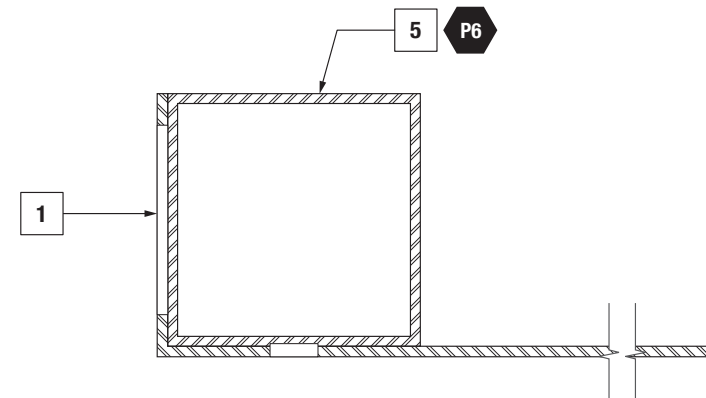

**A SECTION A**  
Scale: 3" = 1'-0"

### NOTES – SIGN TYPE B03

1. MESSAGE PANEL: Minimum 1/4" thick flat aluminum panel with paint finish. Provide UV protective clear coat. Sign panel to wrap around sign post. Message panel to be plug welded to post. Grind, fill and sand smooth all welds prior to painting.
2. SIGN MESSAGE: Surface printed graphics.
3. SIDE PANEL MESSAGE: Reversed cut out letters. Sign post color to show thru.
4. REAR PANEL GRAPHICS: Surface printed graphics on backside of sign panel
5. SIGN POST: 6" Aluminum square post with top capped and paint finish.
6. ATTACHMENT: Steel post to be directly embeded into concrete footing, Sign post to sleeve onto embeded post and secured with tamper proof stainless steel mechanical fasteners.
7. CONCRETE FOOTING: Sign fabricator is responsible for the engineering of the concrete footing.

### GENERAL NOTES

- A. MEASUREMENTS & LOCATIONS: Sign Contractor to field verify all measurements and conditions, and determine final sign locations with owner and RJM prior to creating shop drawings and/or digging the footing.
- B. DESIGN INTENT: Drawings display design intent. Sign Contractor to verify efficacy of fabrication and installation methods proposed with designer prior to creating shop drawings.

# Detail Drawings

## B04 - Pedestrian Directory Static

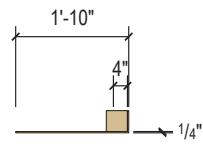

**4 PLAN VIEW**  
Scale: 1/4" = 1'-0"



**5 CONTEXT ELEVATION**  
Scale: 1/4" = 1'-0"

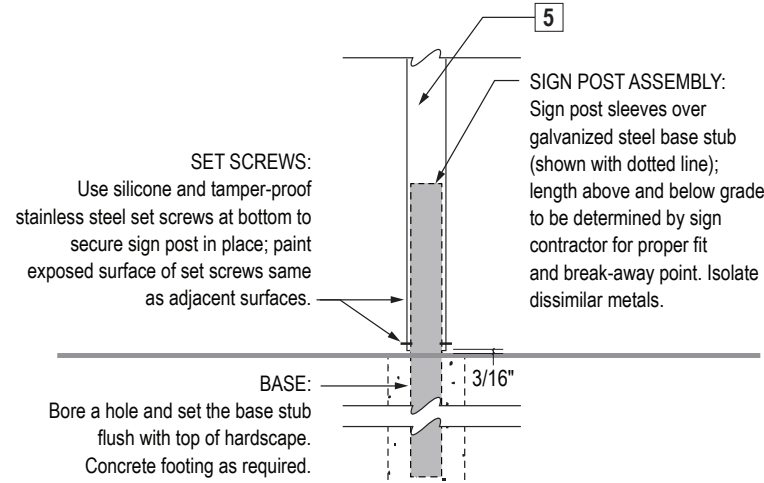

**6 POST DETAIL**  
Scale: N.T.S.

### NOTES – SIGN TYPE B04

1. MESSAGE PANEL: Minimum 1/4" thick flat aluminum panel with paint finish. Provide UV protective clear coat. Sign panel to wrap around sign post. Message panel to be plug welded to post. Grind, fill and sand smooth all welds prior to painting.
2. SIGN MESSAGE: Surface printed graphics. Full color digital print map directory graphics
3. SIDE PANEL MESSAGE: Reversed cut out letters. Sign post color to show thru.
4. REAR PANEL GRAPHICS: Surface printed graphics on backside of sign panel
5. SIGN POST: 4" Aluminum square post with top capped and paint finish.
6. ATTACHMENT: Steel post to be directly embeded into concrete footing, Sign post to sleeve onto embeded post and secured with tamper proof stainless steel mechanical fasteners.
7. CONCRETE FOOTING: Sign fabricator is responsible for the engineering of the concrete footing.

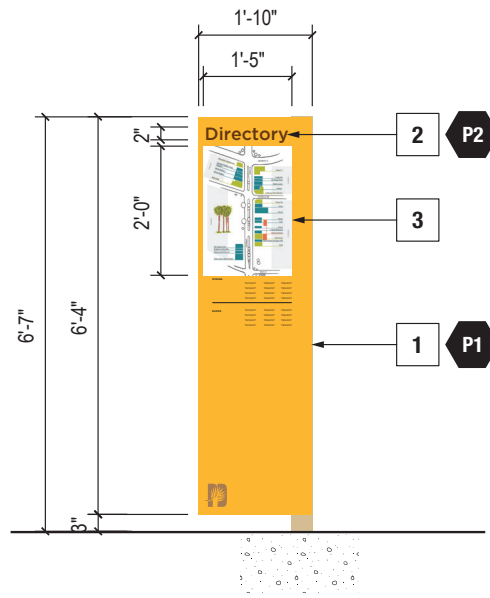

**1 FRONT ELEVATION**  
Scale: 3/8" = 1'-0"

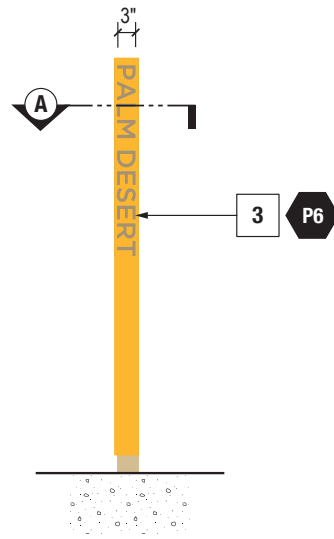

**2 SIDE ELEVATION**  
Scale: 3/8" = 1'-0"

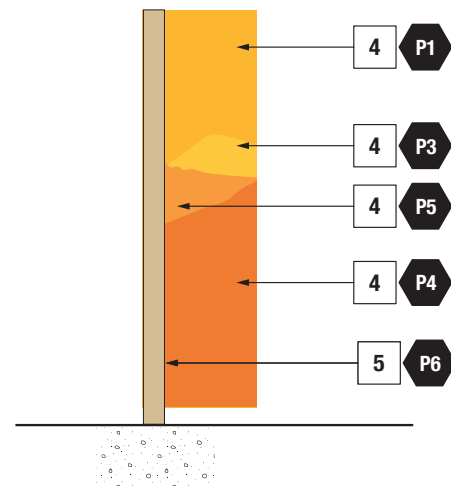

**3 REAR ELEVATION**  
Scale: 3/8" = 1'-0"

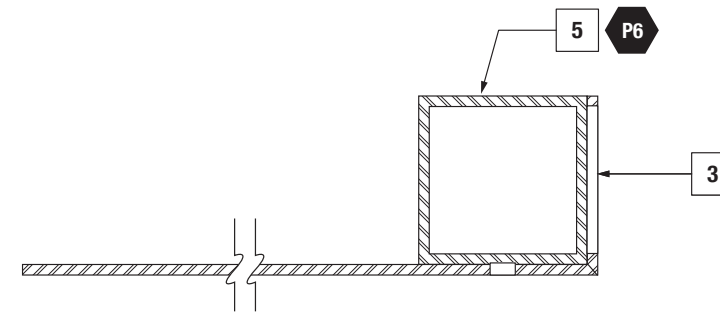

**A SECTION A**  
Scale: 3" = 1'-0"

### GENERAL NOTES

- A. MEASUREMENTS & LOCATIONS: Sign Contractor to field verify all measurements and conditions, and determine final sign locations with owner and RJM prior to creating shop drawings and/or digging the footing.
- B. DESIGN INTENT: Drawings display design intent. Sign Contractor to verify efficacy of fabrication and installation methods proposed with designer prior to creating shop drawings.

5

Sign Location Plan

# Sign Location Plan

The sign location plan presented on the following pages outlines the approved and proposed sign placements, developed through a combination of stakeholder feedback and the comprehensive analysis conducted at the start of this document. These locations reflect key decision points, circulation patterns, and visibility requirements identified during the planning process.

The accompanying chart summarizes the recommended sign types—previously detailed in the summary of sign types and approved designs—and provides a breakdown of the quantities needed to implement a complete and cohesive wayfinding system throughout the area.

Type	Description	Details	Qty
A01	Gateway Monument		1
A02	Gateway Monument Secondary		1
A03	Gateway Monument Tertiary		1
B01	Vehicle Direction Large		40
B02	Vehicle Direction Medium		16
B03	Vehicle Direction Small		3
B04	Pedestrian Direction		4
Subtotal:			66

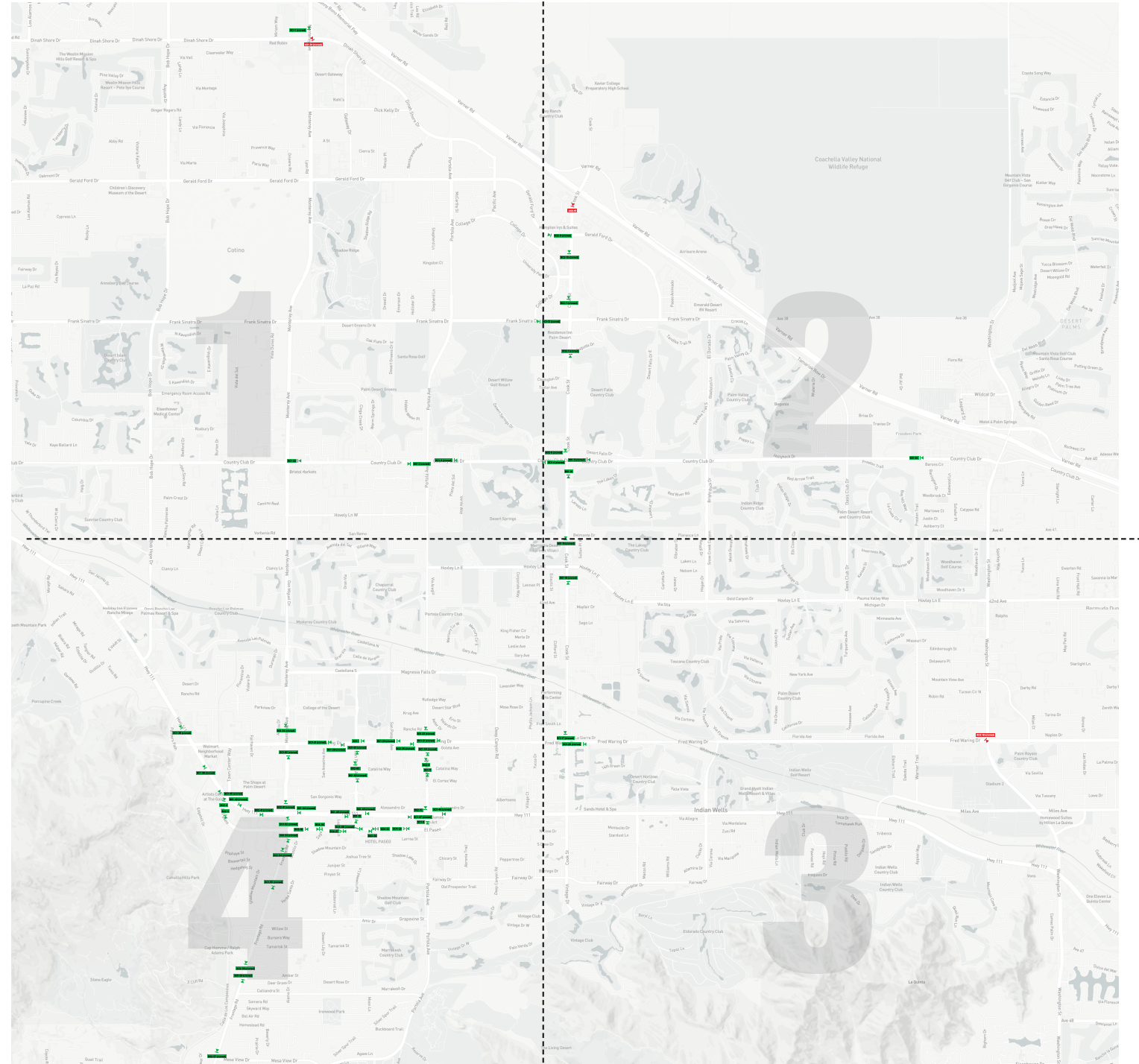

# Sign Location Plan

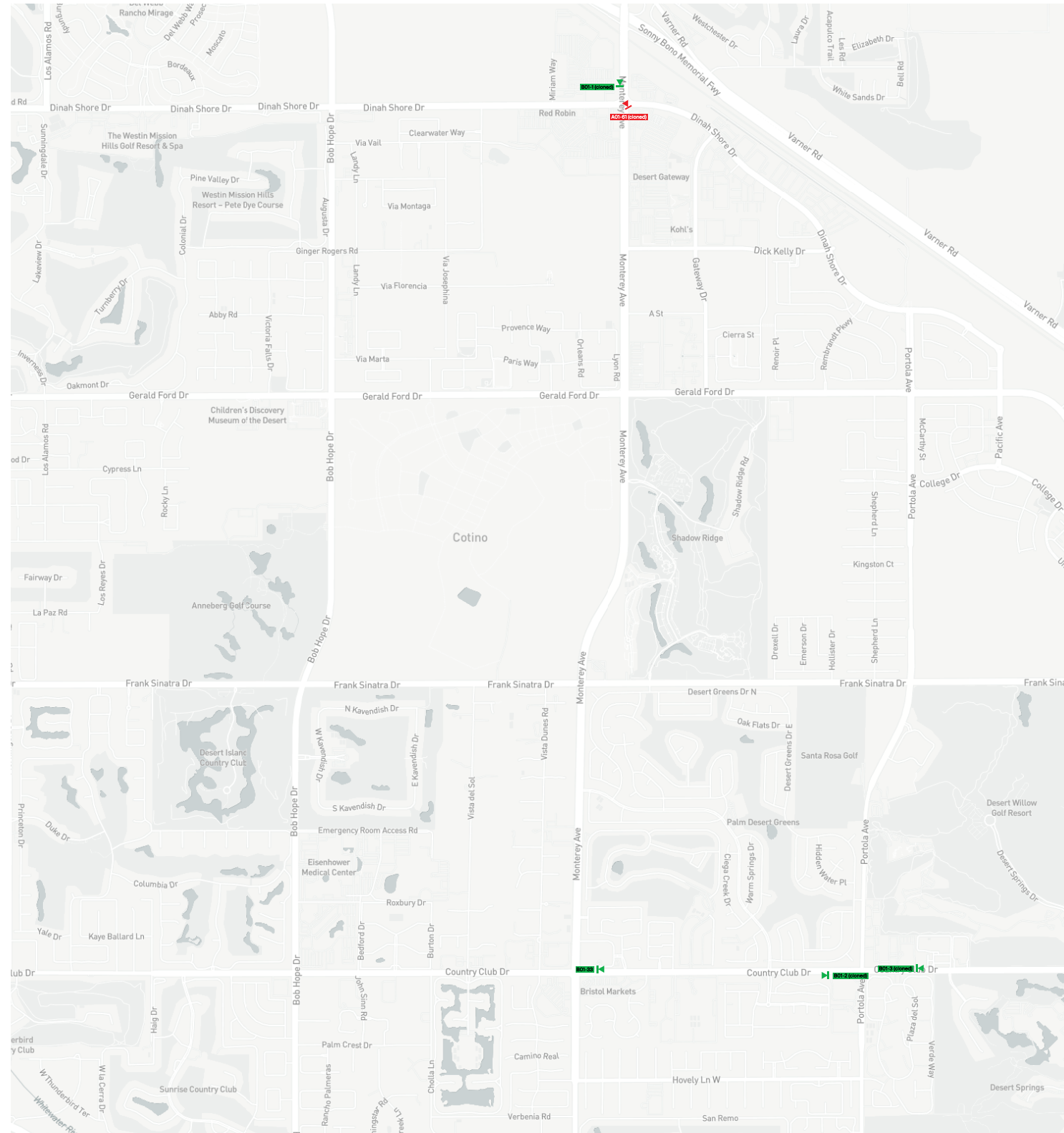

Type	Description	Details	Qty
AD1	Gateway Monument		1
AD2	Gateway Monument Secondary		1
AD3	Gateway Monument Tertiary		1
AD4	Vehicle Direction Large		40
AD5	Vehicle Direction Medium		16
AD6	Vehicle Direction Small		3
AD7	Pedestrian Direction		4
Subtotal:			66

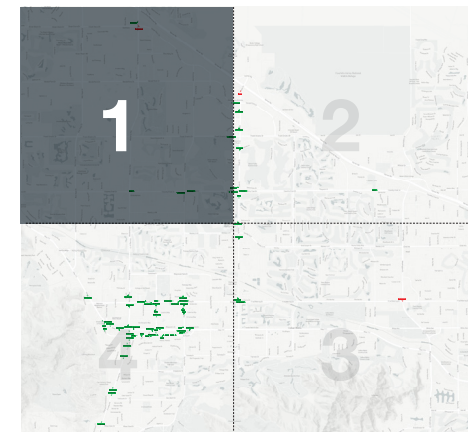

# Sign Location Plan

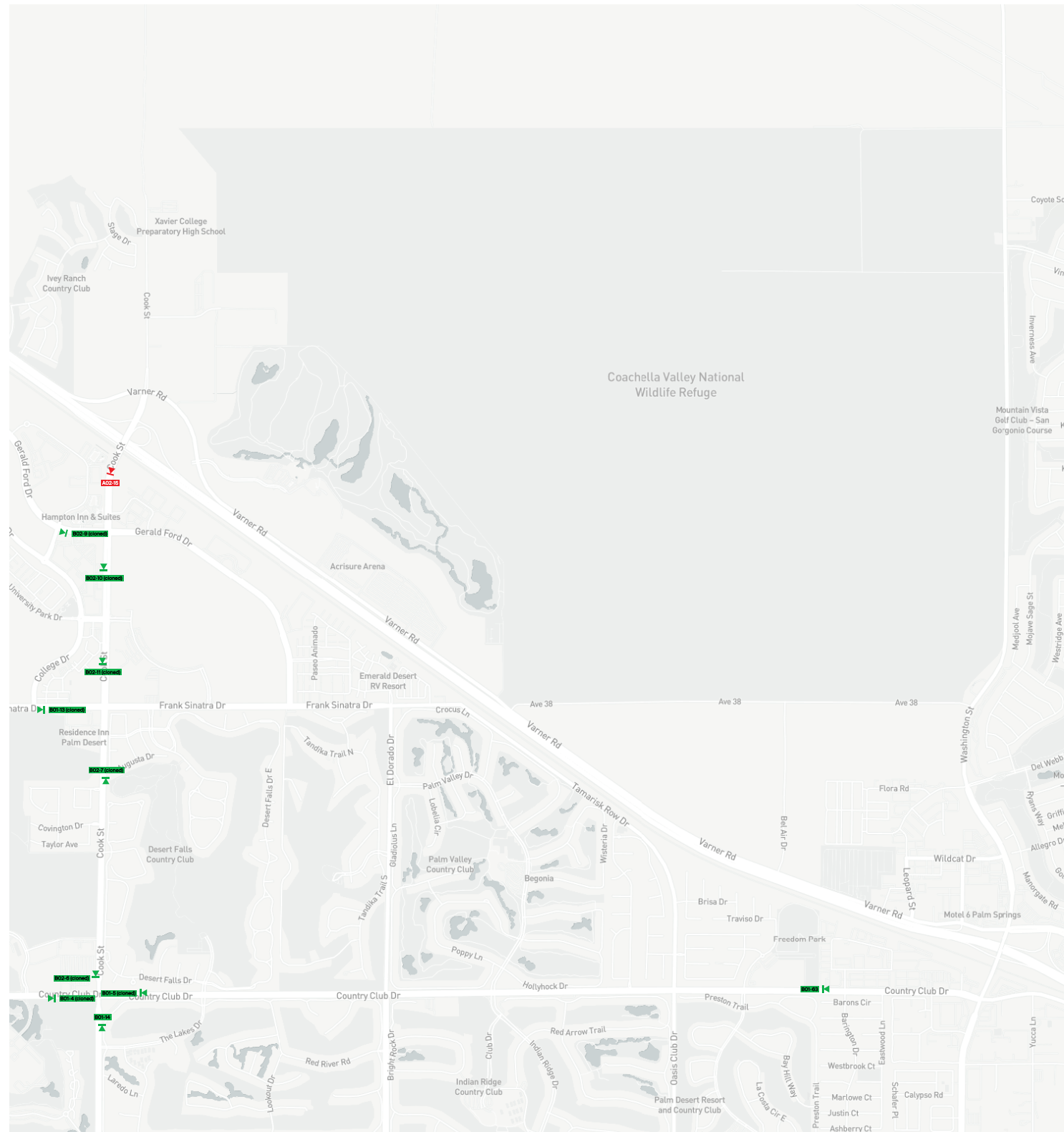

Type	Description	Details	Qty
ADM	Gateway Monument		1
ADM	Gateway Monument Secondary		1
ADM	Gateway Monument Tertiary		1
VDL	Vehicle Direction Large		40
VDM	Vehicle Direction Medium		16
VDS	Vehicle Direction Small		3
PED	Pedestrian Direction		4
Subtotal:			66

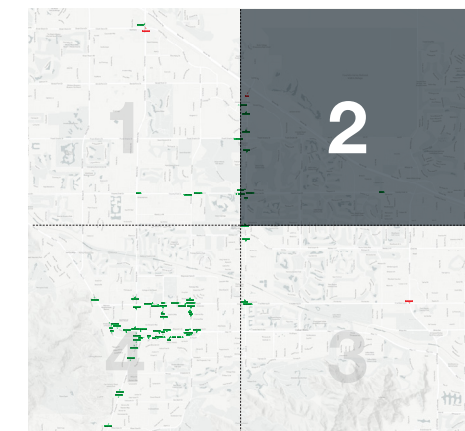

# Sign Location Plan

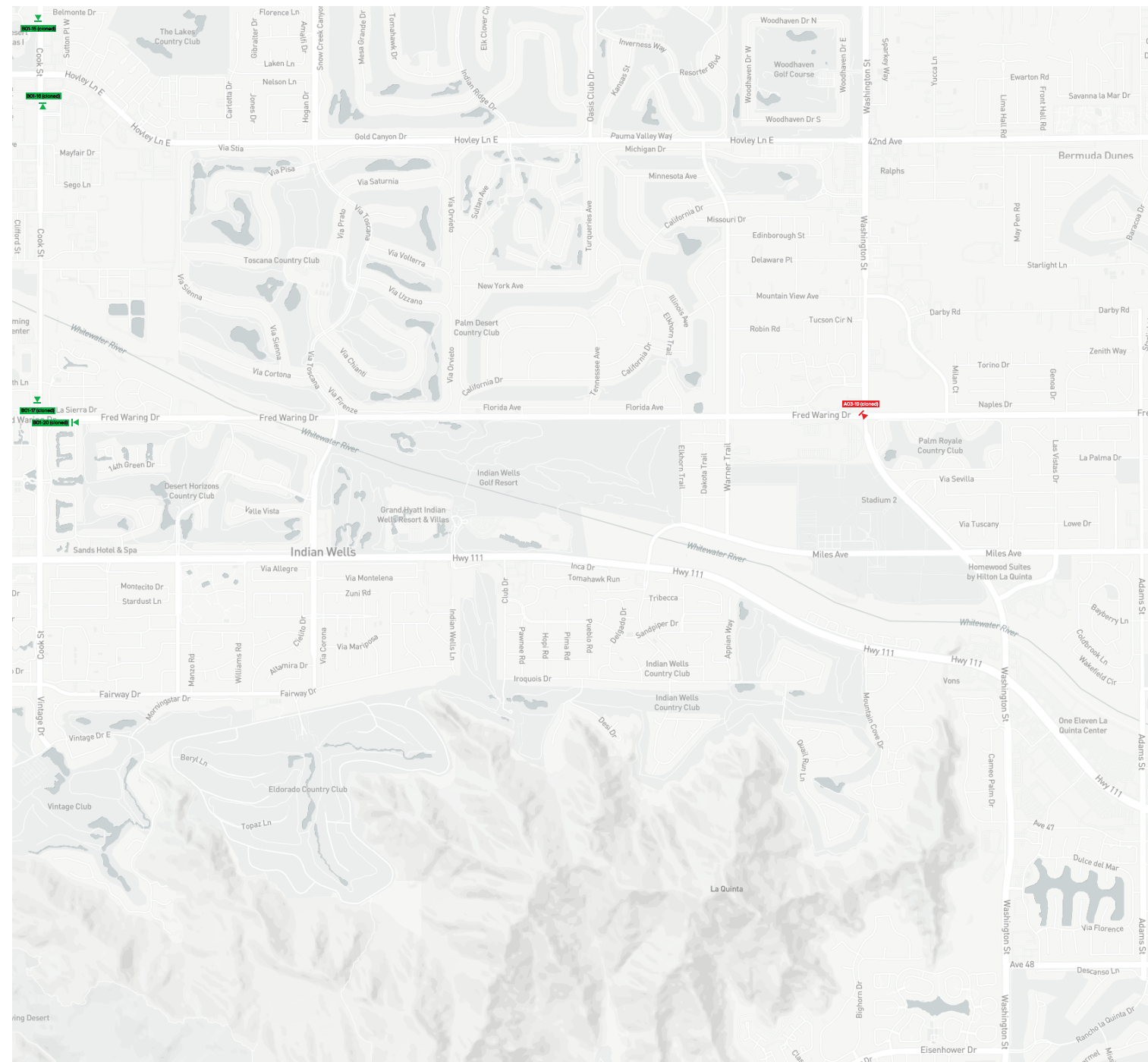

Type	Description	Details	Qty
AD1	Gateway Monument		1
AD2	Gateway Monument Secondary		1
AD3	Gateway Monument Tertiary		1
VDL	Vehicle Direction Large		40
VDM	Vehicle Direction Medium		16
VDS	Vehicle Direction Small		3
PD	Pedestrian Direction		4
Subtotal:			66

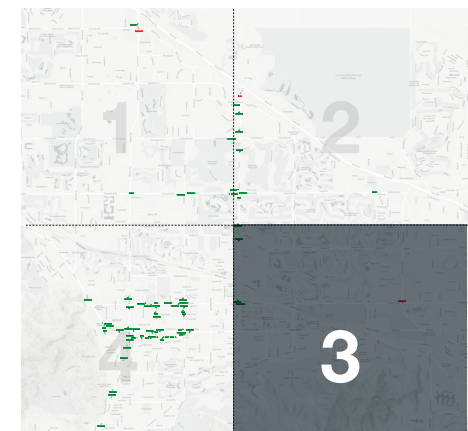

**PROJECT:**  
CITY OF PALM DESERT  
WAYFINDING MASTER PLAN

**PHASE:**  
TASK 4  
JANUARY 05, 2025

# Sign Location Plan (In Progress)

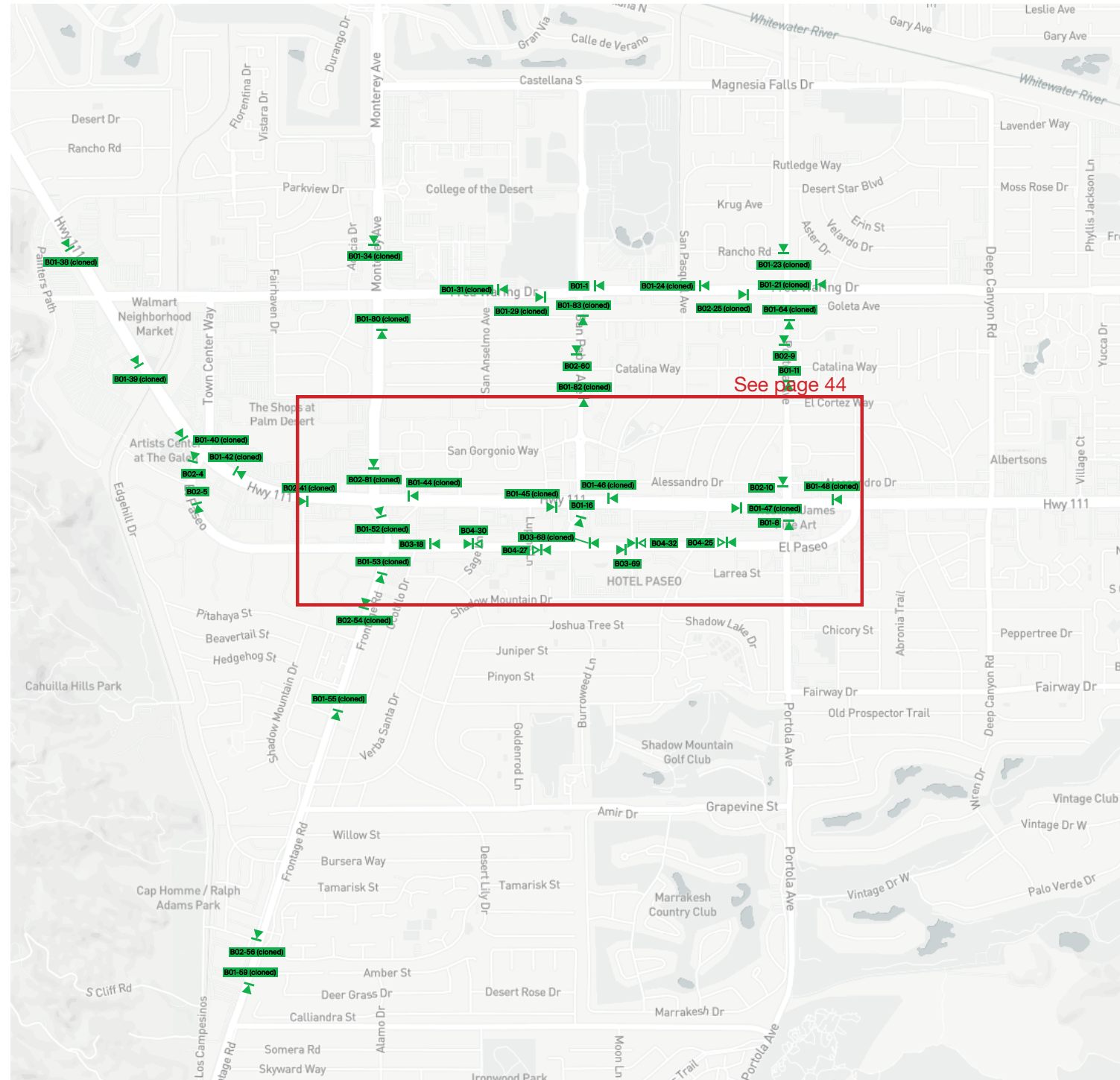

Type	Description	Details	Qty
AD1	Gateway Monument		1
AD2	Gateway Monument Secondary		1
AD3	Gateway Monument Tertiary		1
VD1	Vehicle Direction Large		40
VD2	Vehicle Direction Medium		16
VD3	Vehicle Direction Small		3
PD1	Pedestrian Direction		4
Subtotal:			66

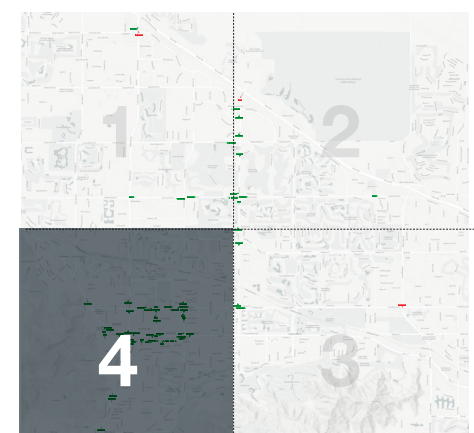

# Sign Location Plan

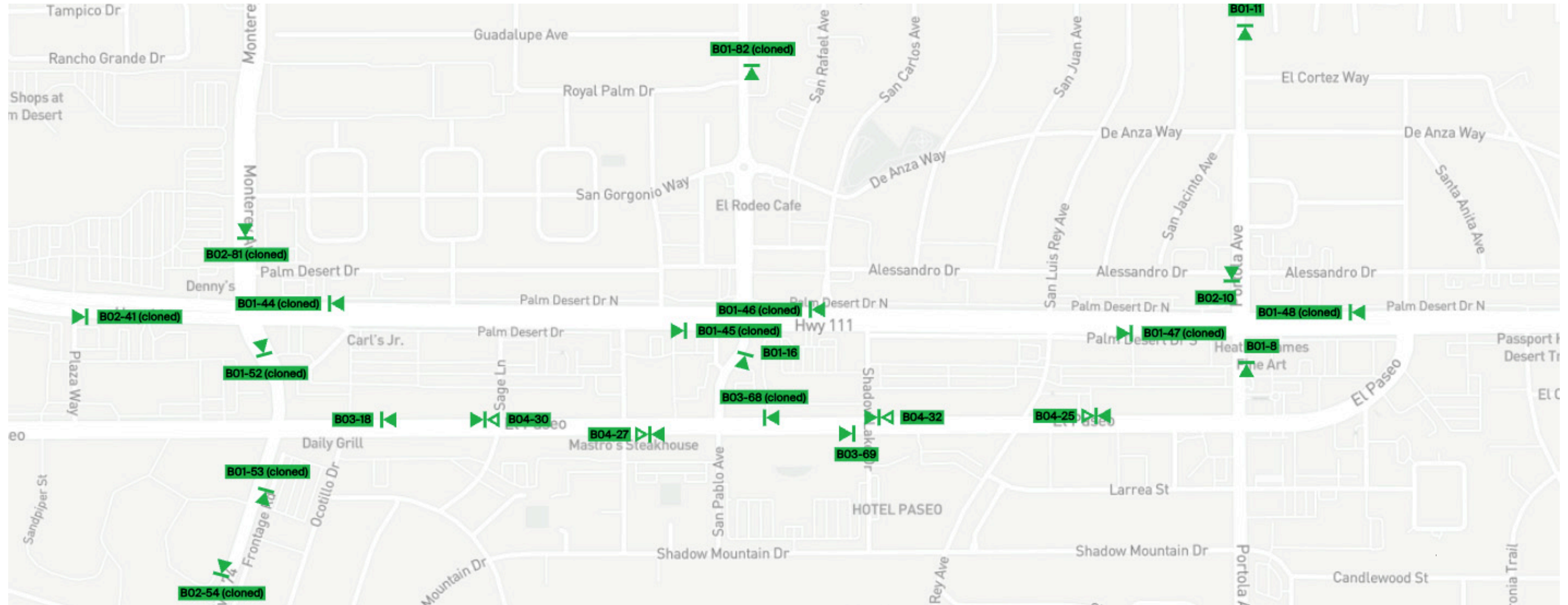

Type	Description	Details	Qty
A01	Gateway Monument		1
A02	Gateway Monument Secondary		1
A03	Gateway Monument Tertiary		1
V01	Vehicle Direction Large		40
V02	Vehicle Direction Medium		16
V03	Vehicle Direction Small		3
P01	Pedestrian Direction		4
Subtotal:			66

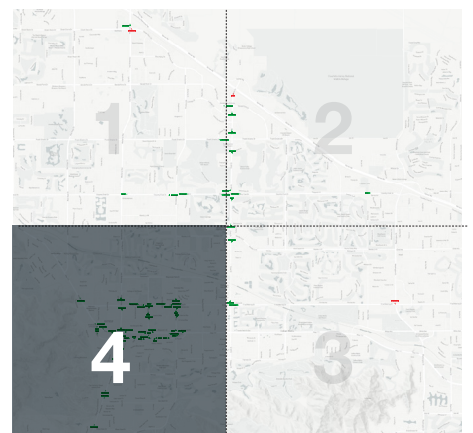

**PROJECT:**  
CITY OF PALM DESERT  
WAYFINDING MASTER PLAN

**PHASE:**  
TASK 4  
JANUARY 05, 2025



Message Schedule

# Message Schedule

#	Quadrant	Sign Type	Street	Recommended Language
1	1	B02-01 (cloned)	Monterey SB	El Paseo (S), McCallum Theatre (S), The Living Desert Zoo (S)
2	1	B02-02 (cloned)	Country Club EB	Desert Willow (E), Civic Center (S)
3	1	B02-33	Country Club WB	College of the Desert (S), McCallum Theatre (S), El Paseo (S)
4	2	B02-04 (cloned)	Country Club EB	CSUSB (N), UCR (N), Freedom Park (E)
5	2	B02-05 (cloned)	Country Club WB	CSUSB (N), UCR (N), Desert Willow (E)
6	2	B01-13 (cloned)	Frank Sinatra EB	UCR (E), CSUSB (N), Desert Willow (S)
7	2	B01-14 (cloned)	Cook NB	Desert Willow (W), CSUSB (N), UCR (N), Freedom Park (E)
8	2	B01-15 (cloned)	Cook SB	Hovley Soccer Park (W), Civic Center (S), College of the Desert (S), McCallum Theatre (S)
9	2	B01-63 (cloned)	Country Club WB	Freedom Park (W), Desert Willow (W), CSUSB (W), UCR (W)
10	2	B02-06 (cloned)	Cook SB	Desert Willow (W), Freedom Park (E)
11	2	B02-07 (cloned)	Cook NB	UCR (E), CSUSB (N)
12	2	B02-09 (cloned)	Gerald Ford EB	CSUSB (S), UCR (S)
13	2	B02-10 (cloned)	Cook SB	CSUSB (E), UCR (S)
14	2	B02-11 (cloned)	Cook SB	UCR (E), Desert Willow (S)
15	3	B01-16 (cloned)	Cook NB	Hovley Soccer Park (E), Desert Willow (N), CSUSB (N), UCR (N)
16	3	B01-17 (cloned)	Cook SB	Civic Center (W), College of the Desert (W), McCallum Theatre (W), El Paseo, (W), The Living Desert Zoo (W)
17	3	B01-20 (cloned)	Fred Waring WB	Civic Center (W), College of the Desert (W), McCallum Theatre (W), El Paseo, (W), The Living Desert Zoo (W)
18	4	B02-08 (New)	Portola NB	Civic Center (N), College of the Desert (N), McCallum Theatre (N)
19	4	B01-11 (New)	Portola NB	The Joslyn Center (W), Civic Center (N), College of the Desert (N), McCallum Theatre (N)
20	4	B02-16 (New)	San Pablo NB	Civic Center (N), College of the Desert (N), McCallum Theatre (N)
21	4	B01-21 (cloned)	Fred Waring WB	Civic Center (W), College of the Desert (W), McCallum Theatre (W), El Paseo (S), The Living Desert Zoo (S)
22	4	B01-23 (cloned)	Portola SB	Civic Center (W), McCallum Theatre (W), College of the Desert (W), El Paseo (S), The Living Desert Zoo (S)
23	4	B01-24 (cloned)	Fred Waring WB	Civic Center (N), The Joslyn Center (S), College of the Desert (W), McCallum Theatre (W)
24	4	B01-29 (New)	Fred Waring EB	College of the Desert (N), Civic Center (N), The Joslyn Center (S), El Paseo (S), The Living Desert Zoo (S)
25	4	B02-31 (cloned)	Fred Waring WB	College of the Desert (N), McCallum Theatre (N), El Paseo (S)
26	4	B01-34 (cloned)	Monterey SB	McCallum Theatre (E), Civic Center (E), El Paseo (S), The Living Desert Zoo (S)
27	4	B01-38 (cloned)	Highway 111 SB	McCallum Theatre (E), College of the Desert (E), Civic Center (E), El Paseo (S), The Living Desert Zoo (S)
28	4	B02-39 (cloned)	Highway 111 SB	Entrada Del Paseo (S), Artists Center (S), Eric Johnson Gardens (S)
29	4	B01-40 (cloned)	Highway 111 SB	El Paseo (S), Cahuilla Hills Park (S), Historical Society (S), The Living Desert Zoo (E)
30	4	B02-42 (cloned)	Highway 111 WB	Cahuilla Hills Park (S), Historical Society (S)
31	4	B01-44 (cloned)	Highway 111 WB	El Paseo (S), McCallum Theatre (N), College of the Desert (N), Civic Center (N)
32	4	B01-45 (cloned)	Highway 111 EB	El Paseo (S), Civic Center (N), College of the Desert (N), McCallum Theatre (N), The Living Desert Zoo (E)
33	4	B01-46 (cloned)	Highway 111 WB	El Paseo (S), Civic Center (N), College of the Desert (N), McCallum Theatre (N)
34	4	B01-47 (cloned)	Highway 111 EB	El Paseo (S), The Living Desert Zoo (S), Civic Center (N), College of the Desert (N)
35	4	B01-48 (cloned)	Highway 111 WB	El Paseo (S), Civic Center (N), College of the Desert (N), McCallum Theatre (N), The Living Desert Zoo (S)
36	4	B02-52 (cloned)	Monterey SB	El Paseo (E), Historical Society (W), Cahuilla Hills Park (W)
37	4	B01-53 (cloned)	Monterey NB	El Paseo (E), The Living Desert Zoo (E), College of the Desert (N), McCallum Theatre (N), Historical Society (W)
38	4	B02-64 (cloned)	Portola NB	Civic Center (W), College of the Desert (W), McCallum Theatre (W)
39	4	B02-80 (cloned)	Monterey NB	College of the Desert (N), McCallum Theatre (E), Civic Center (E)
40	4	B01-82 (cloned)	San Pablo NB	The Joslyn Center (E), Civic Center (N), College of the Desert (N), McCallum Theatre (N)
41	4	B02-83 (cloned)	San Pablo NB	Civic Center (N), College of the Desert (W), McCallum Theatre (W)
42	4	B02-04 (New)	Town Center Way SB	Cahuilla Hills Park (W), Historical Society (S)
43	4	B02-05 (New)	Town Center Way NB	Cahuilla Hills Park (W), Entrada Del Paseo (W), Artists Center (W), Eric Johnson Gardens (W)
44	4	B02-09 (New)	Portola SB	The Joslyn Center (W), El Paseo (S), The Living Desert Zoo (S)
45	4	B02-10 (New)	Portola SB	El Paseo (S), The Living Desert Zoo (S)
46	4	B02-25 (cloned)	Fred Waring EB	El Paseo (S), The Living Desert Zoo (S), Desert Willow (N)



## Message Schedule

47	4	B02-41 (cloned)	Highway 111 EB	El Paseo (S), The Living Desert Zoo (E)
48	4	B02-56 (cloned)	Highway 74 SB	Homme Adams Park (W)
49	4	B02-59 (New)	Highway 74 NB	Homme Adams Park (W), El Paseo (N)
50	4	B02-60 (New)	San Pablo SB	The Joslyn Center (E), El Paseo (S)
51	4	B02-81 (cloned)	Monterey SB	El Paseo (S), The Living Desert Zoo (E)
52	4	B03-18 (New)	El Paseo WB	Parking (N)
53	4	B03-68 (New)	El Paseo WB	Parking (N)
54	4	B03-69 (New)	El Paseo EB	Parking (S)
55	4	B04-25 (New)	El Paseo WB	Pedestrian Level Wayfinding
56	4	B04-27 (New)	El Paseo EB	Pedestrian Level Wayfinding
57	4	B04-30 (New)	EL Paseo WB	Pedestrian Level Wayfinding
58	4	B04-32 (New)	El Paseo WB	Pedestrian Level Wayfinding



# Message Diagrams

# Message Diagrams

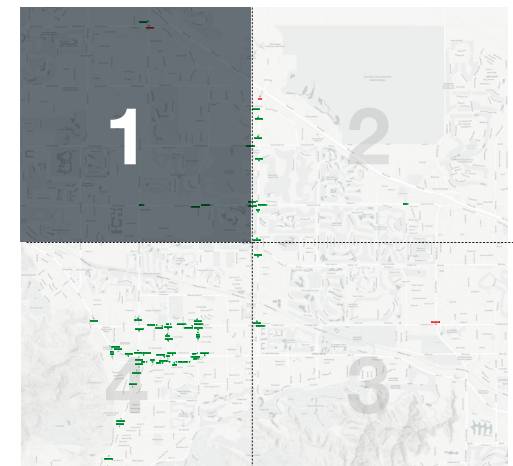
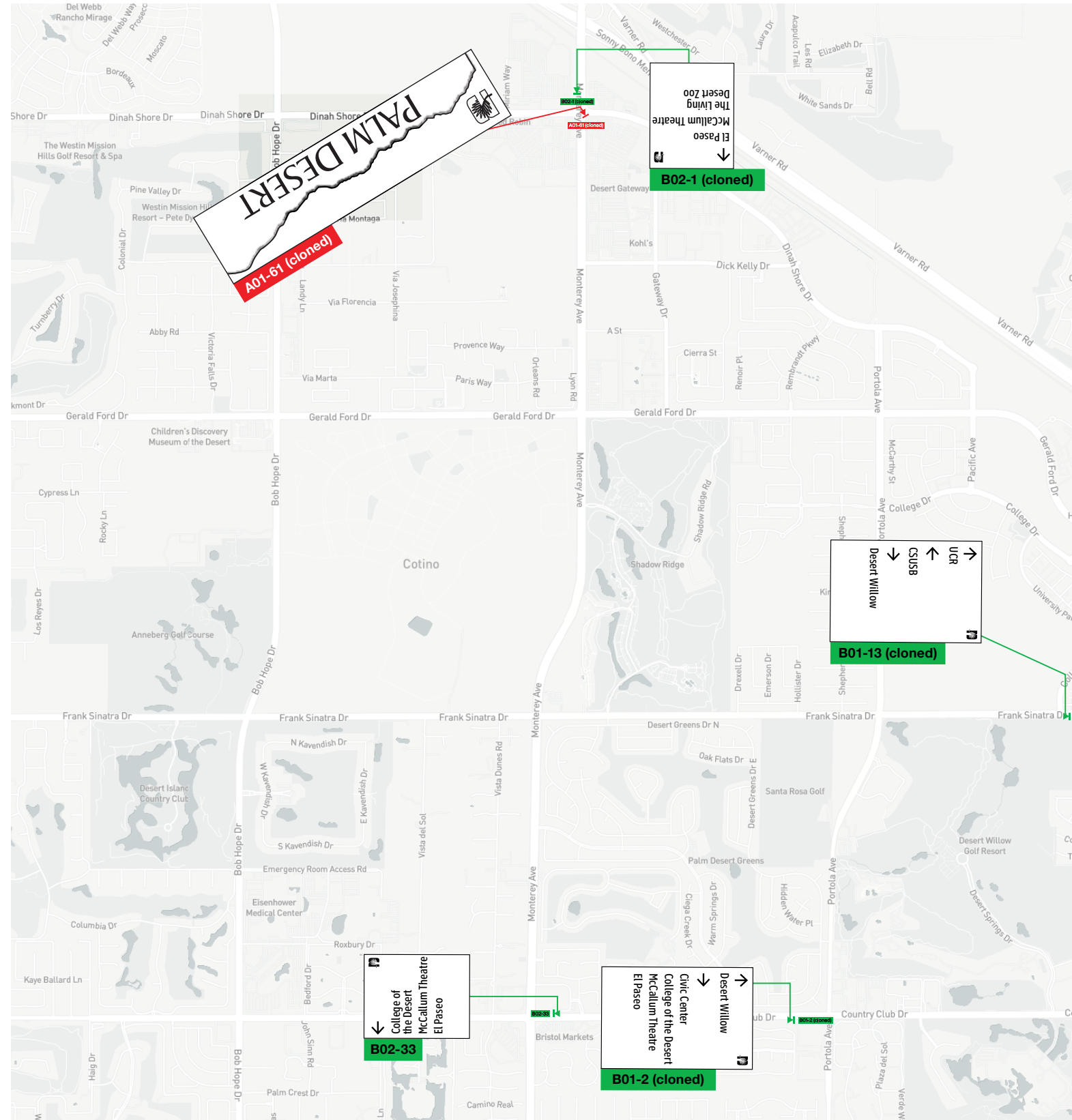

# Message Diagrams

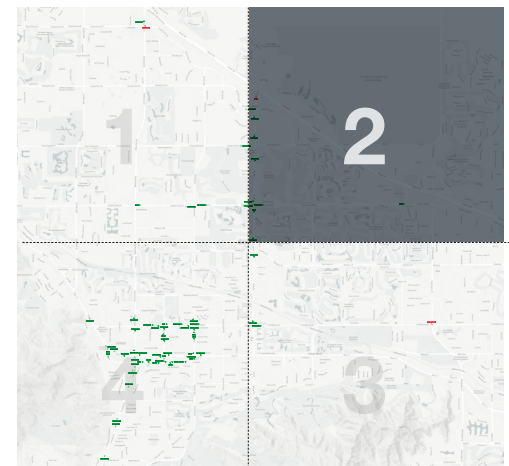
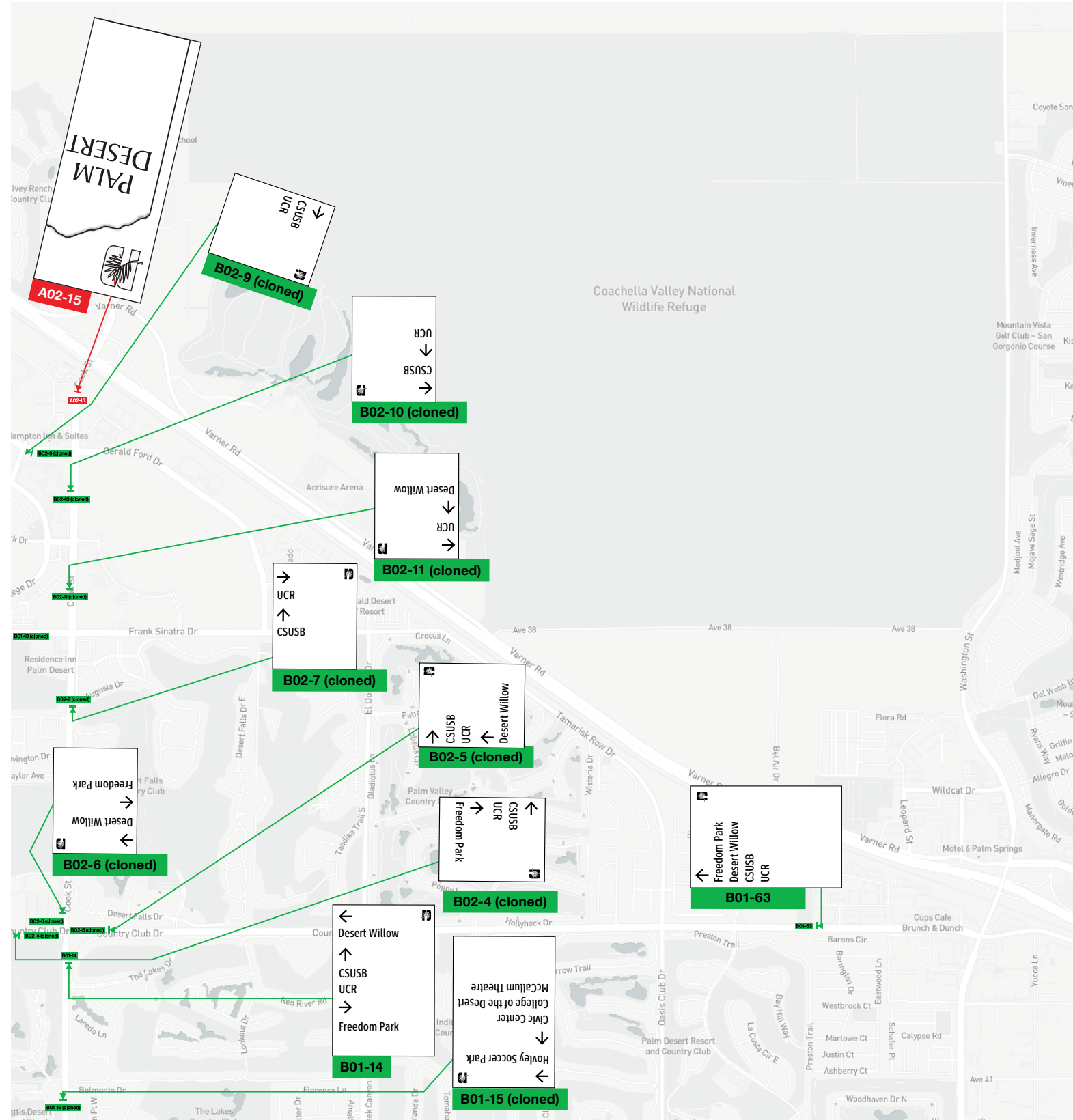

# Message Diagrams

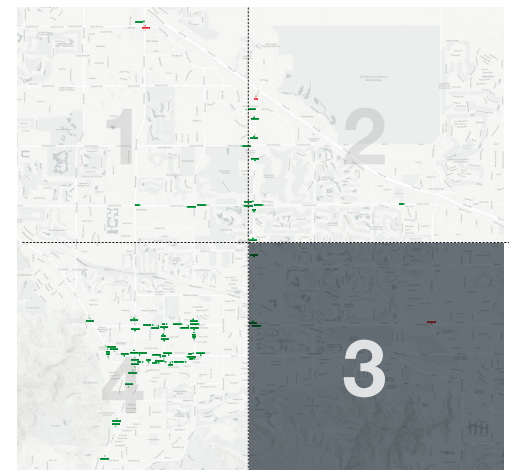



# Message Diagrams

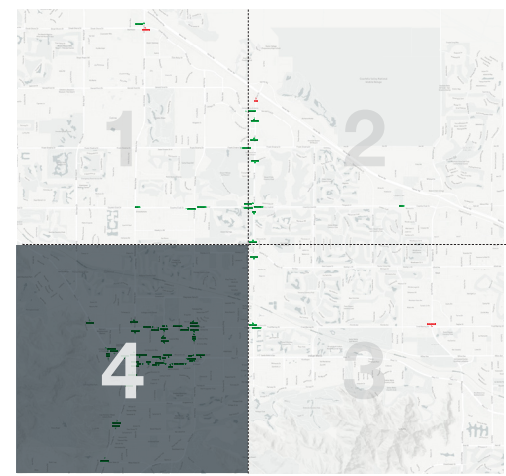
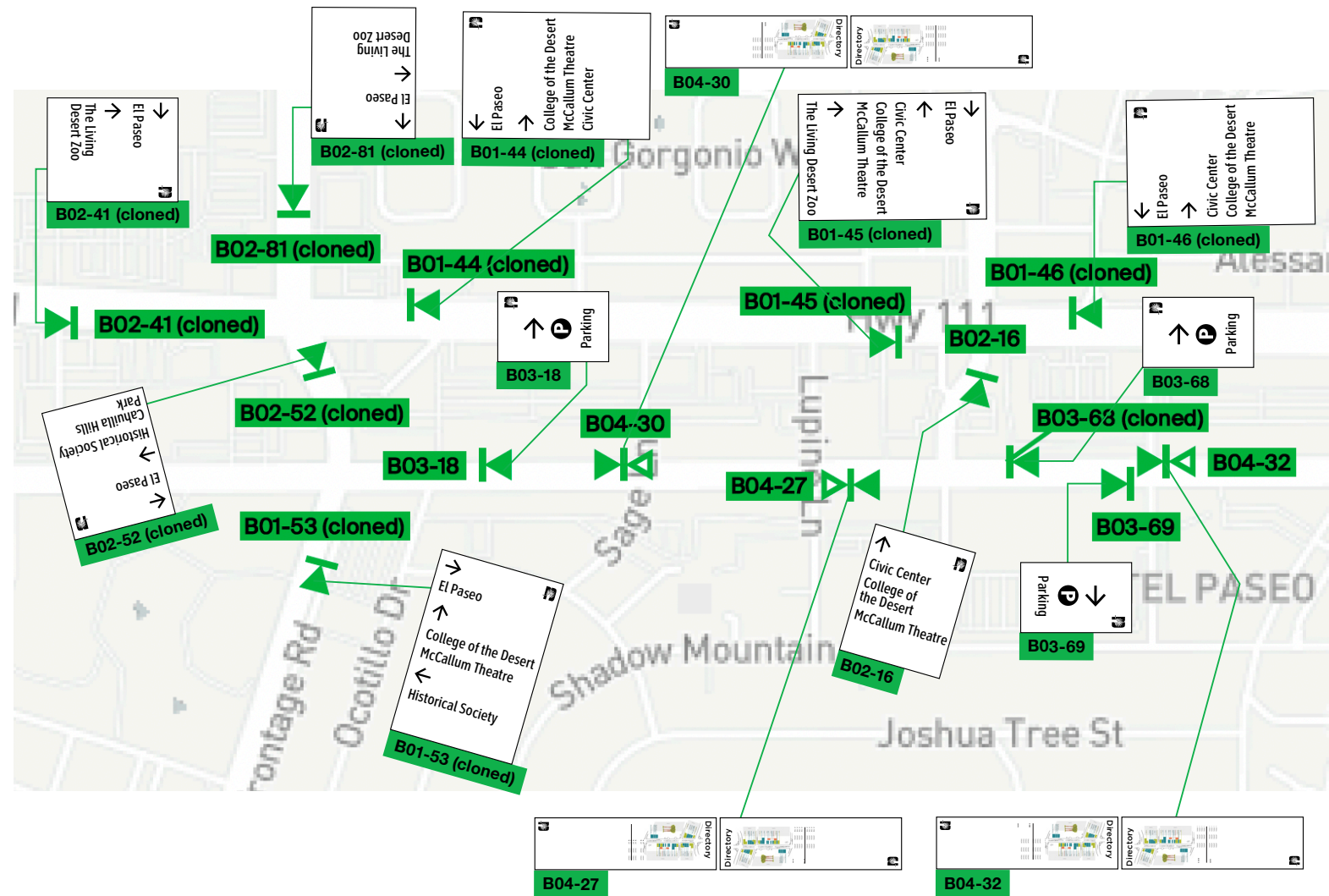

# Message Diagrams

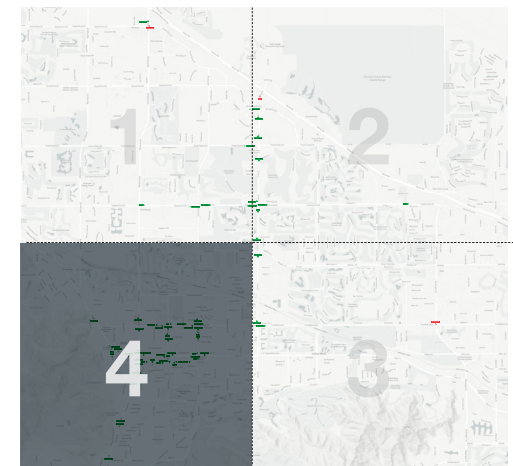
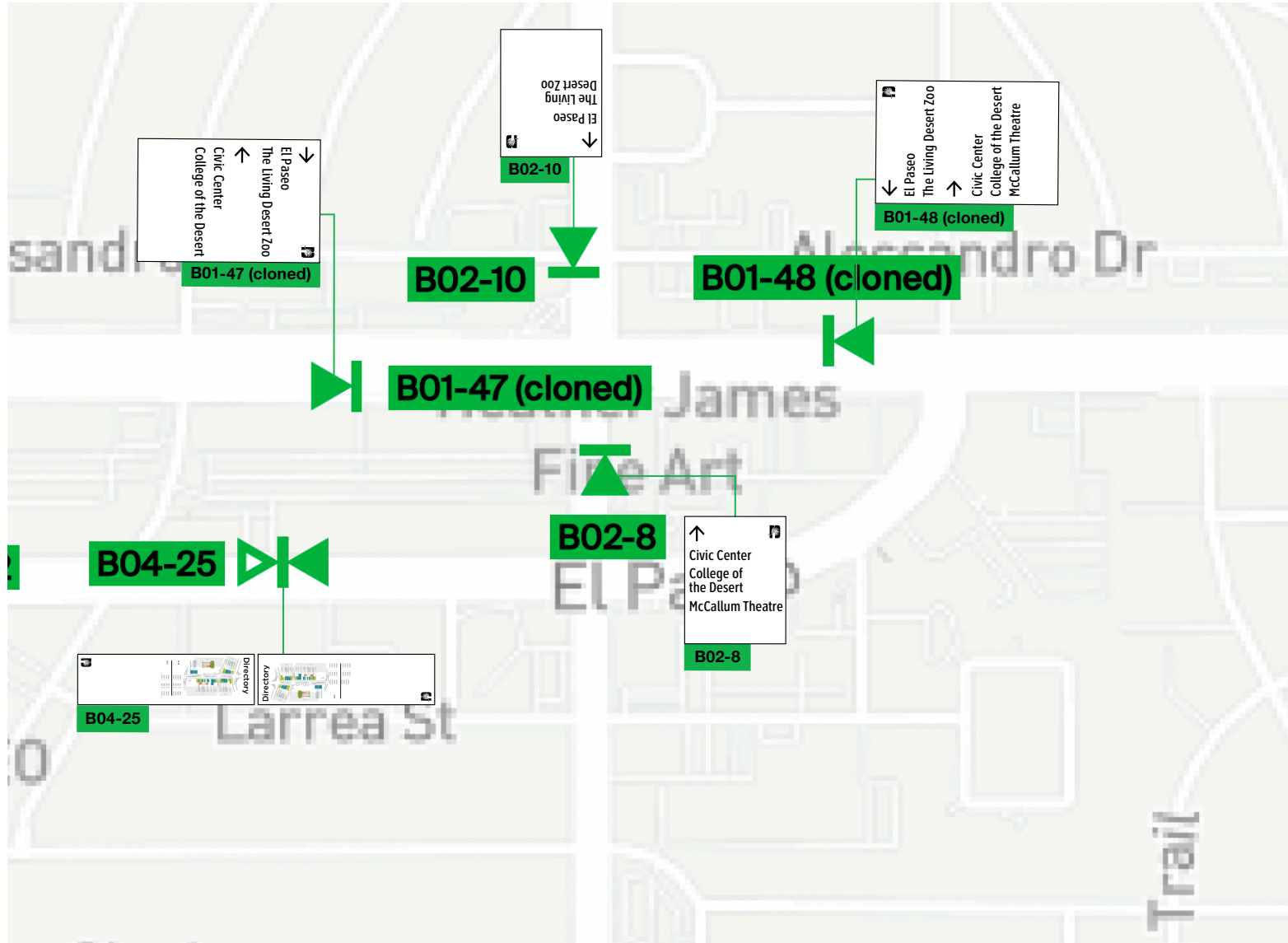



Specifications

# Specifications

## PART 1: GENERAL

### 1.01 – QUALITY ASSURANCE

#### A. Mock-ups and Prototypes:

1. Provide a mock-up of each sign type at the fabrication facility or on-site for review. The mock-up should be a 1:1 scale fabrication of the proposed sign type. The mock-up of a smaller portion of the full-scale sign type may be acceptable if indicated in the Contract Drawings and agreed to by the City's signage representative.
2. Utilize the same materials and installation methods in the mock-up as intended for the final Work. Schedule the installation so that the mock-up may be examined, and any necessary adjustments made, prior to commencing fabrication of the final Work. Replace unsatisfactory items as directed.
3. For freestanding signs, the Sign Contractor is to demonstrate how the sign will be mounted to ground or footing to ensure acceptable stability, level placement and concealed attachments based on structural calculations.
4. When accepted, mock-up shall serve as the standard for materials, workmanship, and appearance for the Work throughout the project.

#### B. Work-In-Progress Approvals:

1. Provide work-in-progress sign elements reviews. Scheduled or unscheduled viewings at the Fabrication Facility may be initiated by the City's signage representative as deemed necessary to ensure continued quality control and make any adjustments required during fabrication. Unsatisfactory items are to be corrected by the Signage Contractor as directed by the City's signage representative.

#### C. Regulatory Requirements:

1. Comply with applicable requirements of the laws, codes, ordinances and regulations of Federal, State, and Municipal authorities having jurisdiction.
2. Obtain necessary approvals and permits from all such authorities as required.

#### D. Markings and Labels:

1. Locate markings, labels, manufacturer names and other identifications so as to be concealed from public view and as acceptable by the City's signage representative unless required by code to be visible.
2. No trade name or other identification shall appear on any item where it will be seen by the public, except as specifically approved by the City's signage representative in advance.

#### E. Final Location of Signs:

1. The location of signs as shown on the Location Plans is for general reference only and in some cases is not representative of the exact final location. Final locations of Signs shall be field verified in coordination with the City's signage representative.
2. The Signage Contractor shall arrange for meetings at the Project site to accommodate direction of final locations according to Project Construction Schedule.
3. The final location of signs shall be submitted along with shop drawings to the City's signage representative.

#### F. Lettering:

1. The Signage Contractor shall be responsible for the quality control of all lettering. All letterforms shall be crisp, sharp, free of nicks, ragged edges and discontinuous curves. All lettering shall conform to approved typeface, weight and letter spacing. No substitutions of typeface foundry, brand,

version or implementation technique will be accepted without approval.

2. Vinyl Die Cut Graphics: All artwork shall be approved vector files for cutting.

3. All cutting and routing shall be executed in such a manner that all edges and corners of finished letterforms are true and clean. Letterforms with rounded positive or negative corners, nicked, cut, or ragged edges, etc., will not be accepted. All letterforms shall be so aligned as to maintain a baseline parallel to the sign format. Margins must be maintained as specified in the Contract Drawings.

4. All Work under the Agreement shall be performed by skilled craftsmen under supervision of trained foremen, experienced in the trade of craft required to accomplish the Work and produce a product of high quality.

G. Tactile Sign Messages:

1. All tactile sign messages must comply with current CBC/LABC sections 11B-703.2 through 11B-703.4.

2. Character spacing shall be measured between the two closest points of adjacent raised characters within a message, excluding word spaces. Where characters have rectangular cross sections, spacing between individual raised characters shall be 0.125-inch (3.2 mm) minimum and 4 times the raised character stroke width maximum. Where characters have other cross sections, spacing between individual raised characters shall be 0.0625-inch (1.6 mm) minimum and 4 times the raised character stroke width maximum at the base of the cross sections, and 0.125-inch (3.2 mm) minimum and 4 times the raised character stroke width maximum at the top of the cross sections. Characters shall be separated from raised borders and decorative elements 0.375-inch (9.5 mm) minimum.

3. Braille shall be contracted Braille (Grade 2), domed compliant with CBC/LABC Table 11B-703.3.1, and maintain a minimum 0.375-inch clear-space from other tactile elements.

4. Braille messages shall be proof-read by the Signage Contractor prior to fabrication. The Signage Contractor shall be responsible to provide certification of true and accurate Braille translations for each message.

H. High Quality of Workmanship:

1. The Signage Contractor shall be responsible for the high quality of all materials and workmanship required for the execution of the Agreement including materials and workmanship of any firm or individual who act as the Signage Contractor's Sub-Contractor.

2. The Signage Contractor shall be responsible for

providing up-to-date shop drawings, specifications, graphic schedule, etc., to all sub-contractors.

I. Dimensions:

1. Written dimensions on drawings shall have precedence over scaled dimensions.

2. The Signage Contractor shall verify and be responsible for all dimensions and conditions shown in the Contract Drawings and shall verify scale and dimensions in any architectural drawings provided. Shop details must be approved by the City's signage representative prior to fabrication.

3. The Signage Contractor to verify dimensions at existing install locations where signage will be mounted to ensure proper fit, spacing and alignment as shown in the Contract Drawings.

J. Discrepancies:

1. The Signage Contractor shall notify the City's signage representative at once of any discrepancies in the Contract Drawings, including but not limited to the detail drawings, sign location plans or sign message schedules. As well as any discrepancies found in field dimensions, conditions or changes that require additional/revised shop drawings.

K. Regulatory Requirements:

1. Comply with applicable portions in current ADA Standards for Transportation Facilities (US DOT), current ADA Standards for Accessible Design (US DOJ), current CBC, and current LABC.

2. Comply with ASCE-21 section 11.5. ASCE 21 also refers to compliance with NFPA-130

3. References:

a. California Building Code – California

Fire Code – Title 24

b. California Public Safety Codes – Title 19

c. California Environmental Protection – Title 27

d. National Association of Architectural Metal Manufacturers (NAAMM) "Metal Finishes Manual."

e. American Welding Society (AWS) – AWS D1.1 "Structural Welding Code, Steel," and AWS D1.2 "Structural Welding Code, Aluminum."

f. Underwriters Laboratories Inc. (UL) – Standards for Safety, UL Publication 48 "Electric Signs."

1.02 – WARRANTY

A. Signage Warranty:

1. After the successful completion of all the signs in the Contract Drawings and after the City's signage representative's acceptance of the finished product, the Sign Contractor shall submit to the City's signage representative a 5-year written warranty covering all Signs, notarized by the Signage Contractor and Installer (if Sub-Contractor is used), agreeing to repair or replace the Defective Signs. Upon notification of such Defective Signs within the warranty period, make necessary repairs or replacement at the convenience of the City.

B. Linear Polyurethane Paint Factory Finish Warranty:

1. After the successful completion of all the signs in the Contract Drawings and after the City's signage representative's acceptance of the finished product, the Sign Contractor shall submit to the City's signage representative a 5-year written warranty covering all Signs, notarized by the Signage Contractor and Installer (if Sub-Contractor is used), agreeing to repair or replace the Defective Signs. Upon notification of such Defective Signs within the warranty period, make necessary repairs or replacement at the convenience of the City.

a. Excessive Fading: A change in appearance that is perceptible and objectionable as determined when visually compared with the original color range standards.

b. Excessive Non-Uniformity: Non-uniform fading to the extent that adjacent panels have a color difference greater than the original acceptable range of color.

c. Will Not Pit or Otherwise Corrode: No pitting or other type of corrosion, discernible from a distance of 10' (3 m), resulting from the natural elements in the atmosphere at the project site.

1.03 – MAINTENANCE & MANUALS

A. Maintenance and Operating Manuals:

1. Submit one (1) PDF or Word document

1. Digital copy of Maintenance and Operating Manuals to city representative.
2. Furnish complete manuals describing the materials, devices and procedures to be followed in operating, cleaning and maintaining the Work. Include manufacturers' brochures and parts lists describing the actual materials used in the Work, including metal alloys, finishes, electrical components and other major components.
3. Assemble manuals for component parts into single digital folders identified for each system.

**B. Instruction:**

1. Prior to acceptance, establish an instruction and training program for City personnel.
2. Notify the city in writing at least seven (7) days prior to commencement of the program providing an outline of topics indexed to the Maintenance and Operating Manual.
3. Provide a trained instructor. Provide three (3) consecutive 4-hour periods of training scheduled during the normal 8-hour working day. Instruction and training shall include, but shall not be limited to, procedures for normal day-to-day maintenance and operation of the Work (as applicable).

**PART 2 : FABRICATION SPECIFICATIONS**

**2.01 – PROCEDURES**

- A. Signage shall be complete for proper installation as described in the Contract Drawings.
- B. Finish work shall be firm, well anchored, in true alignment, properly squared, with smooth clean uniform appearance, without holes, cracks, discoloration, distortion, stains, or marks.

- C. Construct all work to eliminate burrs, dents, cutting edges, and sharp corners.
- D. Finish welds on exposed surfaces to be imperceptible in the finished work.
- E. Except as indicated or directed otherwise, finish all surfaces smooth.
- F. Surfaces, which are intended to be flat, shall be without dents, bulges, oil canning, gaps, or other physical deformities.
- G. Surfaces, which are intended to be curved, shall be smoothly free flowing to required shapes.
- H. Conceal all fasteners, except where indicated in Contract Drawings.
- I. Make access panels tight-fitting, light proof, and flush with adjacent surfaces.
- J. Conceal all identification labels and Underwriters Limited labels to conform to Underwriters Limited Codes.
- K. Carefully follow manufacturer's recommended fabricating procedures regarding expansion or contraction, fastening, and restraining of all metals, glass, acrylic and polycarbonate materials.
- L. Exercise care to ensure that painted, polished, and plated surfaces are unblemished in the finished work.
- M. Isolate dissimilar materials. Exercise care to isolate nonferrous metals from ferrous metals.
- N. All illumination shall be even and without hot spots or light leaks.
- O. Ease all exposed metal edges.

- P. Provide miscellaneous metal supports, fasteners or fabrication items required for completion of the work even though not shown or specified in the Contract Drawings.
- Q. Refer to Contract Drawings for sign color specifications and requirements.
- R. Paint finishes shall be Matthews Acrylic Polyurethane with Matthews Primers and Metal Pre-Treatments or approved equal.
- S. Shop painting to be uniform on and around all sign elements to ensure sign elements will withstand all weather conditions.
- T. Mounting plates shall be in conformance with manufacturer's written recommendations and engineered requirements per sign type.

1. CalTrans standard details
2. CalTrans standard posting details for large roadway signs

- U. Sign faces and/or message panels shall be constructed as removable pieces from a frame or structure by concealed fasteners for refurbishing.

**2.02 – MATERIALS**

**A. All Specified Metals:**

1. Aluminum
  - a. Aluminum shall be suitable for ornamental, architectural work. Surface finish shall be smooth, free of extrusion marks or imperfections. Alloy shall be selected to meet the structural requirements of the specific application.
  - b. Aluminum exterior cabinets, spacers, backplates and frames shall be constructed from 0.25-inch aluminum, #4 horizontal

- brushed and clear anodized finish, unless otherwise specified on Contract Drawings.
- c. Aluminum interior plaques shall be constructed from 0.125-inch aluminum, #4 horizontal brushed finish with semi-gloss linear polyurethane clear coat, unless otherwise specified on Contract Drawings.
- d. Aluminum interior fabricated components shall be constructed from 0.125-inch thickness aluminum sheet.
- e. Extruded aluminum shapes shall utilize 6063-T6 aluminum alloys, unless otherwise specified on Contract Drawings.
- f. Aluminum posts shall be constructed from 2-inch square T52 tubes, 0.1875-inch wall thickness and #4 brushed and clear anodized finish with capped ends, unless otherwise specified on Contract Drawings.

## 8 | Specifications

### 2. Stainless Steel:

- a. Stainless steel shall be suitable for ornamental and architectural work. Surface finish shall be smooth, free of all extrusion marks or imperfections. Alloy shall be selected to meet the structural requirements of specific application. Structural metal for concealed framing shall be of galvanized rolled steel or equal as required to satisfy structural requirements. Stainless steel 316 is suitable and should be indicated in the Sign Contractor shop drawings.
- b. Stainless steel exterior cabinets, spacers, backplates and frames shall be constructed from 0.125-inch stainless steel, #4 horizontal brushed and clear anodized finish, unless otherwise specified on Contract Drawings.
- c. Stainless steel interior plaques shall be constructed from 0.125-inch thickness stainless steel sheet, #4 horizontal brushed finish with semi-gloss linear polyurethane clear coat, unless otherwise specified on Contract Drawings.
- d. Stainless steel interior fabricated components shall be constructed from 0.0625-inch stainless steel, unless otherwise specified on Contract Drawings.

### B. Adhesive:

Adhesives required in fabrication and installation of Signs shall be manufactured by Dow Corning or equal.

1. Adhesives shall be of a type formulated to not deteriorate, discolor, delaminate, or fail in adhesion for any reason including exposure to heat, sunlight, weathering or other environmental conditions. Clear or light color types shall be non-yellowing.
2. "VHB" tape such as Polyfoam or "Isotac" contact

adhesive tape manufactured by 3M shall be used in conjunction with silicone adhesives for installation of wall signs, in minimum thicknesses available.

3. One-part silicone adhesives shall be 20 to 30 "shore A" hardness, clear and non-yellowing.

### C. Concrete Installation:

Installation of anchoring devices into concrete slab shall be adjusted to avoid penetrating existing reinforcing structural components contained in the concrete slab. Coordinate with the Architect and Structural Engineer.

### D. Acrylic:

Acrylic intended for non-illuminated use shall be 0.25-inch cast acrylic sheet with non-glare finish, unless otherwise specified on Contract Drawings. Acrylic intended for edge-illuminated use shall be 10mm extruded acrylic sheet with embedded diffuser particles designed specifically for edge-lighting, unless otherwise specified on Contract Drawings.

### E. Plexiglas® and Lexan®:

Plexiglas® shall be manufactured by Rohm and Haas Co., or equal quality. Lexan® polycarbonate resin thermoplastic shall be manufactured by GE Plastics, or equal quality. Thickness shall be as indicated on Contract Drawings or not less than 0.125-inch thick. The Signage Contractor shall provide color and finish samples of all plastics for approval before fabrication; no substitution in color, thickness, or finish of plastics will be accepted without written approval from the City's signage representative. All plastics shall be of uniform color, translucence and illumination, as supplied by manufacturer. Any exposed edges of material shall be finished so as no saw marks are visible.

### F. Hardware/Hinges:

Provide and install all incidental hardware necessary for the proper functioning of the

Signs, including, but not restricted to, materials and products covered in this section. Provide stainless steel hinges for all hinged access panels. Provide pin tumbler locks for all access panels requiring locks. Provide stainless steel fasteners for assembling ferrous and non-ferrous metals.

### G. Fasteners:

All tamper proof bolts, nuts, acorn nuts, screws, washers, lock washers, anchors and other devices required to complete the Work shall use the same basic metal or alloy as the metal fastened, and match in color and texture. Use stainless steel 300 series alloy where used to join dissimilar materials.

### H. Exposed Fasteners:

All exposed fasteners to be 0.125-inch flathead stainless steel screws painted to match adjoining surfaces unless otherwise specified on Contract Drawings.

### I. Pin-mount Supports:

Pin-mount supports shall be 0.1875-inch to 1-inch diameter painted threaded rods with non-corrosive spacer covers painted to match returns as appropriate.

### J. Insulation/Material Isolation:

All ferrous and non-ferrous metals shall be separated with non-conductive gaskets to prevent electrolysis. In addition to gaskets, provide stainless steel fasteners for some cases as required.

### K. Interior Vinyl Graphics:

Applied interior vinyl graphics to be High Performance Cast Vinyl Sheeting, unless otherwise specified on Contract Drawings.

### L. Exterior Vinyl Graphics:

Applied exterior vinyl graphics to be High Performance Reflective Vinyl Sheeting, unless otherwise specified on Contract Drawings.

1. All reflective vinyl shall be minimum 3M Diamond Grade Series 4000, which is CalTrans/LADOT compliant unless otherwise specified on Contract Drawings.
2. All vinyl overlays will be applied over new fabricated metal sign panels with no existing overlays.

### M. Additional Material/Processes:

For materials or processes described in the preceding list, the material and/or process as detailed in the Contract Drawings shall be used as the meet or exceed equivalent.

### N. Outdoor Material Application:

All materials in the preceding list required for outdoor application must be suitable for coastal environments. Any material(s) proposed by the Sign Contractor that is not listed above should be clearly identified in the shop drawings for the City's signage representative's review and approval.

2.03 – ELECTRICAL COMPONENTS

A. Electrical Components:

All electrical components must conform to applicable electrical codes and the following:

1. All materials must be approved and listed by Underwriters Laboratories, Inc.
2. Light Emitting Diode (LED) general lighting requirements:
  - a. Provide sufficient LED wattage, quantities and spacing to ensure continuous, maximum illumination.
  - b. Provide LED lighting prototypes to verify brightness and uniformity of lighting with designer.
3. LED lighting component, color and power requirements:
  - a. Edge lighting – fabricated linear white LEDs 24 VAC.
  - b. Back lighting – fabricated matrix white LEDs 24 VAC.
4. Heavy duty, non-keyed, flush mounted, fused or unfused disconnects. Provide NEMA 1 for dry locations and proper enclosure for others.

B. Electrical Wiring and Equipment:

Provide and install electrical materials such as ballasts, transformers, power supplies, LED modules, lamps, sockets, neon units, connectors, and all other equipment which shall be new and shall be approved by Underwriters Laboratories, Inc. The assembly of all components within the illuminated signs shall conform to all standards of Underwriters Laboratories, Inc. as published in the latest edition of "Standards for Sign Safety" and all illuminated signs

shall bear the U.L. label. All wiring and equipment shall be concealed within the Sign structure.

- C. Conduit and Devices: Provide rigid steel conduit, junction boxes and associated devices in accordance with applicable codes as required.
- D. Wiring: Minimum #12 AWG copper shall be used. High tension wiring shall not be less than GTO 15 wire as manufactured by Carol Cable Company or approved equal. All wiring shall be AWM 90 0 centigrade 1000-volt TW/MTW U.L. file no. 18971. Wiring connectors for wire splicing shall be U.L. approved 1000-volt capacity and shall be Scotch Lock type Y or R or equal. All splices should be easily accessible for inspection and should be shown on shop drawings.
- E. Power Supplies: Ballast and or UL approved power supplies shall be used as required for internally illuminated cabinet signs, in quantity and arrangement as recommended by manufacturer, accessible for maintenance and shown on shop drawings provided by the Signage Contractor.
- F. LED Power Supplies: LED power supplies shall be used as required for internally illuminated cabinet signs, in quality and arrangement as recommended by manufacturer, accessible for maintenance and shown on shop drawings provided by the Signage Contractor..
- G. Disconnect Switch: All Signs or Sign components with electrical service shall be equipped with an approved external disconnect switch, flush mounted on the cabinet / Sign, with circuits and capacity to control all primary wiring within the Sign. Location of switch must be shown on shop drawings and is subject to approval.

- H. LED Illumination: All signs with LED fixtures shall provide even, diffused, illumination without light leaks or hotspots. The Signage Contractor shall provide any specification information required to verify performance. All fixtures shall be provided by the Signage Contractor. The Signage Contractor shall provide waterproof flush access panel(s), which shall be concealed wherever possible. Conduit wiring and electrical equipment from the field electrical connection to any part of the sign and within the sign shall be provided by the Signage Contractor.
- I. Ventilation: While maintaining a proper weather seal, the Signage Contractor shall provide for sufficient ventilation of Sign components to prevent overheating or warping; allowing for color of sign, mounting surface, climate conditions, etc. In providing for ventilation, Signage Contractor shall protect sign from elements (rain, wind, debris, etc.) that might cause operational or cleaning problems. Signs / cabinets with light leaks will not be accepted. the Signage Contractor shall utilize stainless steel bug mesh screen for integration with weep holes or vent / louvers on the Signs to prevent insect migration into illuminated Signs.
- J. IT Conformity: All electrical components are subject to review by the City's IT group. Sign Contractor shall provide all fabrication details and electrical component specifications for all sign types in detailed shop drawings.

2.04 – DYNAMIC VIDEO DISPLAYS

- A. IT Conformity: All Dynamic Screens, Electronic Full Color LCD, LED and OLED Dynamic Video Displays shall conform to the latest City IT department specifications and requirements. Sign Contractor

is to provide all compatible dynamic signage, screens, related equipment and mounting systems per Contract Drawings unless noted otherwise. Sign structural support, internal illumination, electrical/data connections and required custom fabrication details for all sign types should be detailed in shop drawings.

- B. FCC Compliance: Electronic Full Color Dynamic Video Displays must conform to FCC (Federal Communications Commission) Title 47, Part 15, Class A. The Displays must have FCC Compliance statement sticker affixed to the exterior of the product.
- C. Third-party Testing: Upon request, display manufacturer must provide an accredited Third-party Testing Lab Center certificate of compliance for the Display model quoted for the project. The FCC requires that all digital screens be tested in a worst-case scenario to ensure compliance with emissions limits and to show that the equipment will not cause harmful electromagnetic interference to other devices.
- D. Display Statement: All displays must showcase the following statement on the exterior of the displays, as required by 47 CFR section 15.19(a)(3):

- 1. This device complies with part 15 of the FCC Rules. Operation is subject to the following 2 conditions:
  - a. This device may not cause harmful interference.
  - b. This device must accept any interference received, including interference that may cause undesired operation.
- E. Test Plan:
 

The Signage Contractor is required to submit a Test plan for all Dynamic Video Displays in compliance with Division 27 and to include the following:

  - 1. Factory Testing
  - 2. Field Installation Testing
  - 3. Field Functional Testing
- F. Functionality Verification:
 

After successfully installing all displays and components, Sign Contractor to demonstrate to the City's signage representative and verify that all components work seamlessly per Test Plan and manufacturer's specifications.

2.05 – FINISHING MATERIALS

- A. Linear Polyurethane Coatings:
 

The Signage Contractor is required to provide the following, or other products as approved by the City's signage representative.

  - 1. Acrylic Polyurethane Ultra Low VOC Paint: MAP-LV by Matthews Paint Company to be used for exterior application for properly prepared and primed substrates such as aluminum, steel and other substrates. Substrates should be prepared according to the Matthews Substrate Preparation Guide prior to topcoat application.
  - 2. Primer for Aluminum: Two-part component primer: One-coat Matthews 74-734 and 74-735 Metal Pretreat at .25 mils dry film thickness or one-coat Matthews 74-793 Spray Bond at .15 to .25 mils dry film thickness

- or Wyandotte / AKZO Grip-Guard Wash Primer (2Afy-31284) with Grip-Guard Wash Primer Hardener (10AFK-31285) combined and applied per manufacturer's specifications or approved equal (primer) for the application of the pre-approved and pre-formulated paint system.
- 3. Primer for Steel:
 

Two part component primer: One-coat Matthews 74-734 and 74-735 Metal Pretreat at .25 mils dry film thickness or Wyandotte / AKZO Grip-Guard Wash Primer (2Afy-31284) with Grip-Guard Wash Primer Hardener (10AFK-31285) combined and applied per manufacturer's specifications or approved equal (primer) for the application of the pre-approved and pre-formulated paint system.
- 4. Clear Sealers:
 

Crystal clear matte Low VOC or Ultra Low VOC polyurethane sealers by Matthews Paint Co. or approved equal. Sealers are to resist rust and corrosion associated with exposure to salt air. And provide additional UV protection, graffiti resistance and durability. As required and of highest quality available, applied per manufacturer's specifications. Where vinyl, decals, or film are to be applied over painted surfaces, apply clear polyurethane over both applique and paint to provide an anti-graffiti coating.
- B. Anodized Aluminum Components/Panels:
 

If required, the Signage Contractor shall provide anodized (application of aluminum oxide film coating in clear or colored dye finish) aluminum panels or parts to match Contract Drawing specified color, grain, finish and specifications.
- C. Direct Printing Materials:
 

Provide only weather-resistant coating materials, compatible with the intended substrates under normal wear and use the workmanship and materials used should not delaminate, peel, blister, crack or fade for a period of ten (10) years for exterior use. This does not include accidents, abuse or misuse.

- D. Painted or Silk-Screening Materials:
 

Provide only weather-resistant coating materials, compatible with the intended substrates. All silk-screened graphics are to be done with the finest screen size feasible for sharp, even reproduction.
- E. Vinyl Die-Cut and Pattern Cut-out Graphics:
 

Use Scotchcal Opaque and Translucent film and Scotchcal Diamond Grade VIP Reflective film manufactured by 3M where specified. Use pressure-sensitive, non-yellowing, non-peeling and weather resistant vinyl as specified. Use approved fonts and colors as specified. Apply in strict accordance with manufacturer's instructions. Make uniformly smooth and free from bubbles, wrinkles, stretching, and blemishes.

2.06 – FABRICATION OF SIGNS AND SUPPORTS

- A. General:
 

Provide custom manufactured Sign assemblies, components completely fabricated and finished at factory before delivery to Project. Construct to accurate detail and dimensions as shown and as review on approved shop drawings. Fit and assemble the Work at the shop and mark the components as required to facilitate assembly during installation. Exposed fasteners on finished faces will not be allowed, unless specifically indicated. Waviness and oil canning of surfaces is not acceptable. Minimum material thickness is to be 0.090 inches. Conceal wiring, conduct and other electrical items within sign enclosures.
- B. Lettering:
 

Cut and rout in a manner to produce true and clean edges and corners of finished letterforms. Letterforms having rounded positive or negative corners, nicked, cut, or ragged edges are not acceptable. Align letter forms to maintain a baseline parallel to the sign format. Maintain margins as indicated on the Contract Drawings.

- C. Seams and Joints:
 

The Signage Contractor shall cut walls and floors carefully and neatly repair them in an acceptable manner. The Signage Contractor shall consult the Architect of Record in cases where cutting into a structural portion of the building is required so that satisfactory reinforcement may be provided. Added joints shall be ground filled and finished flush and smooth with adjacent work. Such seams shall be invisible after final finish has been applied. Spot welded joints shall not be visible on exterior of signs after final finish has been applied. No gaps, light leaks, waves, or oil canning will be permitted in Work. If any of these are evident, the Signage Contractor will be required to correct its Work or construct a new Sign at its own expense.
- D. Metal Signs and Supports:
 

Fabricate exposed surfaces uniformly flat and smooth, without distortion, pitting, or other blemishes. Form exposed metal edges to a smooth radius. Permanently bond the laminated metal components and honeycomb core

with adhesive or sealant in accordance with product manufacturer's recommendations. Grind exposed welds and rough areas to make flush with adjacent smooth surfaces.

- E. Welding:  
Make welds continuous. Comply with American Welding Society, Aluminum Association, and Copper Development Association standards for the type of metal used.
- F. Fasteners:  
Sign face surfaces shall not be penetrated, deformed, distorted, or discolored by attachment of concealed fasteners. All fasteners and attachment hardware shall be resistant to oxidation or other corrosive action completely through their cross sections. Work shall be secured with fasteners of the same metal, color, and finish as the components they secure when visible. Use exposed fasteners only if shown on the Contract Drawings.
- G. Dissimilar Materials:  
Where metal surfaces will be in contact with dissimilar materials, coat the surfaces with epoxy paint or plate with zinc chromate, or provide other means of dielectric separation as recommended by manufacturer to prevent galvanic corrosion (i.e. Neoprene gasket as an isolation membrane).
- H. Castings:  
Exposed surfaces shall be uniformly free from porosity and roughness. Edges shall be filled and ground smooth. Faces shall be chemically etched and mechanically polished for specified finish.
- I. Galvanizing:  
Provide for steel components in exterior construction, and where noted in Contract Drawings shall be galvanized. Complete the shop fabrication prior to application of the zinc coating. Remove mill scale and rust, clean and pickle the units as required for proper pretreatment of the surfaces.

- J. Hardware:  
Provide all incidental hardware necessary for the proper functioning of signs. External hardware shall conform to the external appearance of the Sign.
- K. Supports and Backing in Walls:  
The Signage Contractor shall provide engineered Sign supports anchored to building structure where required and to meet requirements of applicable building codes. Support or backing requiring installation within the building wall construction shall be immediately relayed to the Architect of Record and the City's signage representative for field coordination. The Signage Contractor shall meet with the General Contractor to review all requirements.
- L. Access Doors and Frames:  
Access doors and frames shall be flush with the material in which they occur, unless otherwise specified. Access doors and frames shall be provided upon prior written approval of the Architect of Record and the City's signage representative. Each trade providing access doors and frames shall verify the need for fire rated doors on the Construction Drawings. Access doors in walls, partitions or ceilings shall bear UL fire rated labels of same fire rating. If access doors and frames are required to be exposed to view, they shall be chrome, brass, stainless steel, or other finish to match other finishes in the spaces in which they are to be installed, unless otherwise specified. Obtain the City's signage representative's approval for location of each access door prior to placement.

2.07 – FINISHES APPLICATION

- A. Sign Graphics:  
Provide the letters, numerals, symbols, and other graphics markings, using the finish materials shown. Apply the graphics neatly, uniformly proportioned and spaced, and accurate

within the dimensions indicated. Prepare the substrate surfaces and apply finish materials in accordance with manufacturers' instructions.

- B. Metal Finishes:  
Remove scratches, abrasions, dents and other blemishes before applying finish. Apply the following to the fabricated Work, with texture and reflectivity as required to match the Architect's sample.
  - 1. Linear Polyurethane Finishes:  
Clean the surfaces as required for proper adhesion of coatings. Use 3M Scotch-Brite™ pads with cleanser and water, and/or chemically treat as recommended by paint manufacturer to remove deleterious film or residue.
  - 2. Linear Polyurethane Primer:  
Provide pretreatment and primer in accordance with manufacturer's recommendation. Add ultraviolet inhibitors to paint subject to sunlight exposure.
  - 3. Clear Linear Polyurethane Finish:  
Provide pretreatment, primer, and matte or semi-gloss finish coatings in accordance with manufacturer's recommendations and Contract Drawings. Apply 1.5 to 2.0 mils (0.0375 to 0.050 mm) dry film thickness.

2.08 – GRAPHICS APPLICATION

- A. Preparation:  
Surfaces to receive the graphic markings shall be clean, dry, and otherwise made ready for application of the materials. Accurately measure and lay out the required marking configurations as indicated on Contract Drawings. Graphic applications include but are not limited to the following.
- B. Vinyl Die-cut and Pattern-cut Graphics:

Use pressure sensitive, non-yellowing, non-peeling and weather resistant vinyl adhesive letters or images, custom flood coated as required, die cut from Scotchcal™ or Scotchlite™ as manufactured by 3M Company. Apply in strict accordance with manufacturer's instructions. Make uniformly smooth and free from bubbles, wrinkles, stretching and blemishes.

- C. Direct Printing Graphics:  
All digital pictorials to output at a true minimum [720x720] dpi output resolution. Files to contain a minimum of 200 pixels per inch at final size. Under normal wear and use the workmanship and materials used should not delaminate, peel, blister, crack or fade for a period of ten (10) years for exterior use. This does not include accidents, abuse or misuse.
- D. Painted or Silk-screened Graphics:  
All graphics shall be applied using photo processed screens from camera ready art, arranged to furnish sharp and solid images without build-up or bleeding of the coating. Comply with coating manufacturer's application instructions. Provide proper type of primer to suit each substrate and obtain a permanent bond. Verify compatibility of each substrate with the coatings to be used in

the Work. Apply the markings with neat edges, minimum 3 mils (0.075 mm) dry film thickness and as required to obtain solid markings without voids.

4. Acid-Etched Graphics and Typography:

Acid-etched typography and graphic imagery must be an average of 1/16-inch deep, with clean, crisp, sharp edges; ragged or soft (polished out) edges will be rejected. Acid baths used for etching should be fresh and used in an environment and temperature that will provide the highest quality etched images. Color fill as indicated by the S/P color and finish schedule, keeping inks and fills true to the edges of letterforms/graphics.

PART 3: EXECUTION

3.01 – VERIFICATION OF CONDITIONS

- A. Inspect all surfaces to receive signage and report all defects that would interfere with signage installation.
- B. Starting Work implies acceptance of surfaces as satisfactory.
- C. Verify all conditions and sign dimensions in field. the Signage Contractor to review and study architectural, landscape, lighting, electrical and related plans to ensure that all proposed signs can be installed and supported. Verification of conditions and sign dimensions to be completed prior to sign fabrication and reviewed with the City's signage representative.

3.02 – DEMOLITION

- A. Existing signage to be removed and responsibly and lawfully disposed.
- B. To support the City's environmental sustainability policies all materials, where practicable, should be recovered and recycled prior to commencement of work when maintenance or general replacement is undertaken.
- C. Installation of new signage to be installed immediately after any demolition.
- D. Unused data and/or electrical feeds to be coordinated with with city representative for proper terminations.
- E. Any surfaces damaged shall be repaired and painted/patched to match adjacent surface.
- F. Concrete and floor surfaces to be repaired in coordination with city representative.

3.03 – INSTALLATION

- A. Install signage upon acceptance by the City's signage representative of material and completion of job site area to receive such materials.
- B. Guard against damaging existing pavements and planting where Sign is to be installed.
- C. Footings beneath topping surface shall be installed and located prior to top surface installation.
- D. Prior to installation, check all components, nuts, bolts, and other connections for proper alignment, fit and any damage. Replace damaged or defective components.
- E. Prior to installation, confirm all electrical locations and requirements with the

City's signage representative.

3.04 – CLEANUP

- A. Keep areas of work clean, neat and orderly at all times. Clean surfaces, inside and out. Use approved cleaners if necessary, to remove dirt, smudges, stains or grime.
- B. Protective coverings and strippable films shall be removed at a time that will afford the greatest protection of the installed Work. Sign adjacent surfaces shall be cleaned to remove excess glazing and sealant compounds, dirt, and other substances.
- C. Upon completion of work and before final acceptance, remove tools, surplus materials, apparatus, and debris from the site. Wash, clean, and leave paved areas without stains. Leave the site in a neat, clean condition for review by the City's signage representative.

3.05 – FINAL INSPECTION AND ACCEPTANCE

- A. Upon completion of work, the City's signage representative will perform a final inspection for acceptance.
- B. The Sign Contractor shall remove all unused mock-ups, submittals, materials, and equipment from site prior to final acceptance by the City's signage representative.
- C. The Sign Contractor shall submit to the City's signage representative all operation manuals, tools, and keys as specified in this Document.

- END OF SECTION -

Maintenance Schedule

All signs, in inventory storage and public areas, shall be inspected and cleaned bi-annually to maintain a high quality finish and achieve longevity. In addition, site-wide inspections shall occur after earthquakes, power outages, heavy rainfall, and high wind conditions.

Signage Inventory Oversight and Inspections

Regular sign inventory inspections and information will be managed by city representative.

Oversight responsibilities include:

- Sign inventory
- Photographic archives
- Damage Report/Repair Request documents
- Specifications
- Shop drawings
- As-builts drawings
- Field verification for sign types, messaging, location
- Warranties

The signage inspector shall maintain a photographic archive of each sign. Dated record updates will occur upon sign installation and at regular inspections.

Regular scheduled signage inspections

shall include the following steps:

1. Physical inspection and photographic documentation.
2. Completion of the Damage Report/Repair Request.

The Inspection Damage Report/Repair Request will detail all damage and repairs needed and confirm completion of these tasks:

- a. Complete photographic documentation
- b. Note message updates where applicable
- c. Enter message updates into database (upon validation)
- d. Remove damaged signs promptly
- e. Check and test all illuminated signs to ensure proper performance
- f. Tighten screws, bolts, and fasteners periodically  
Replace missing fasteners promptly
- g. Check sign cabinets and support structures for cracks and vandalism
- h. Remove broken components and replace promptly
- i. Clean graffiti immediately
- j. Touch up damaged paint promptly
- k. Cleaning

Graffiti & Vandalism

All signs shall be covered in removable transparent anti-graffiti film which can be easily replaceable.

For all cleaning or maintenance issues, please contact city representative.

Cleaning

All signs shall be cleaned to a professional standard. Tape, grime, dirt, and graffiti shall be removed. Most surfaces can be cleaned with mild soaps and detergents applied with a soft lint-free cloth or sponge.

Cleaning methods shall include but not be limited to the following:

1. No aggressive solvents, paint thinners, acetone, alcohol, and chemical cleaners shall ever be used.
2. No scouring pads and cleaners containing abrasives which can scratch finishes shall ever be used.
3. Exterior signs shall be washed with automobile cleaner and warm water.
4. Tape shall be removed with 3M vinyl tape remover agent.
5. Light graffiti can be removed with citrus-based products and pressurized clean water. Signs which can not be cleaned of graffiti shall be refurbished or replaced.
6. Electronic and dynamic display signs shall be cleaned according to the manufacturer's recommendations.