

**CULTURAL ARTS COMMITTEE  
CITY OF PALM DESERT  
STAFF REPORT**

---

MEETING DATE: July 9, 2025

PREPARED BY: Erica Powell, Management Analyst

SUBJECT: CONSIDER PURCHASE OF RISING INVERSION SCULPTURE BY  
CRISTOPHER CICHOCKI

---

**RECOMMENDATION:**

Recommend that the City Council approve expenditure in the amount of \$150,000 for the purchase of *Rising Inversion* by artist Cristopher Cichocki (cha-house-key), to be permanently installed at Ironwood Park.

**BACKGROUND/ANALYSIS:**

*Rising Inversion* is a large-scale, site-specific sculpture originally commissioned by the Laguna Art Museum for its 11th annual Art & Nature program. Fabrication of the artwork was fully funded by the Museum, and the sculpture is now available for purchase at a cost that reflects the significant investment already made in its creation.

The artwork, measuring 12 feet tall by 40 feet long and weighing approximately 3,000 pounds, is constructed in a spherical formation with a depth ranging from five feet at the center to one foot at the edges. The surface is coated with a phosphorescent pigment that absorbs sunlight during the day and emits a soft glow at dusk, gradually fading as night falls—creating an immersive and interactive public art experience.

Ironwood Park, located at 47800 Chia Drive, is a tranquil desert setting with no existing public art. The proposed placement of *Rising Inversion* will offer residents, visitors, and park users an opportunity to engage with large-scale contemporary art in a serene and contemplative outdoor space.

In addition to its artistic merit and interactive quality, *Rising Inversion* holds special significance as the work of Cristopher Cichocki, a Palm Desert native whose internationally recognized career in contemporary art reflects the City's ongoing commitment to nurturing and celebrating local talent.

**Grant Funding Background:**

In 2024, staff submitted *Rising Inversion* for consideration under the National Endowment for the Arts (NEA) Our Town grant. The project was deemed ineligible due to administrative criteria unrelated to the artistic quality or community impact of the proposal. In 2025, the project was again submitted under the ARTS in California Parks grant program, but it did not advance to the application stage. No specific reason for this decision was provided.

Despite these grant outcomes, the value of the sculpture and the opportunity it presents for community engagement and cultural enrichment remain clear. Staff therefore recommends direct acquisition of the artwork using approved Public Art funds.

**FINANCIAL IMPACT:**

The total cost for the acquisition and installation of *Rising Inversion* is \$150,000. Funds have been approved and are available in the Capital Projects Public Art Projects account. The artist will be responsible for all site preparation, transportation, logistics, and installation of the sculpture, ensuring minimal impact on City resources.

**ATTACHMENTS:**

1. Presentation for *Rising Inversion* by Cristopher Cichocki
2. Cristopher Cichocki Bio
3. LA Times article
4. Palm Springs Life article
5. Proposed Location at Ironwood Park

# Consider Purchase of *Rising Inversion*

CULTURAL ARTS COMMITTEE PRESENTATION  
CITY OF PALM DESERT



# Recommendation

---

Approve expenditure of \$150,000 from the Capital Projects Public Art Projects account for the purchase of *Rising Inversion* by Cristopher Cichocki (Cha-house-key), to be permanently installed at Ironwood Park.

# Background

---

- *Rising Inversion* was originally commissioned by Laguna Art Museum.
- Fabrication is complete and fully funded by the Museum.
- The 3,000-pound sculpture measures 12 ft x 40 ft, coated with phosphorescent pigment that glows at dusk.

# Artistic and Community Significance

---

- Interactive, large-scale public art installation
- Proposed for Ironwood Park, a serene desert location with no current public art
- Created by Palm Desert native Cristopher Cichocki
- Promotes local talent and expands cultural landscape

# Los Angeles Times

Cristopher Cichocki's 'Rising Inversion' grips viewers with phosphorescent glow



A crowd of guests waits to watch artist Cristopher Cichocki (in orange jacket) unveil "Rising Inversion" on Thursday. (Don Leach / Staff Photographer)



**Rising Inversion**  
(Golden Hour Sideview)

# Fiscal Analysis

---

Total cost for acquisition and installation: \$150,000

The artist will be responsible for:

- Site preparation
- Transportation and logistics
- Installation

Funds approved and available in Public Art Capital Projects account.

# PALM SPRINGS LIFE.

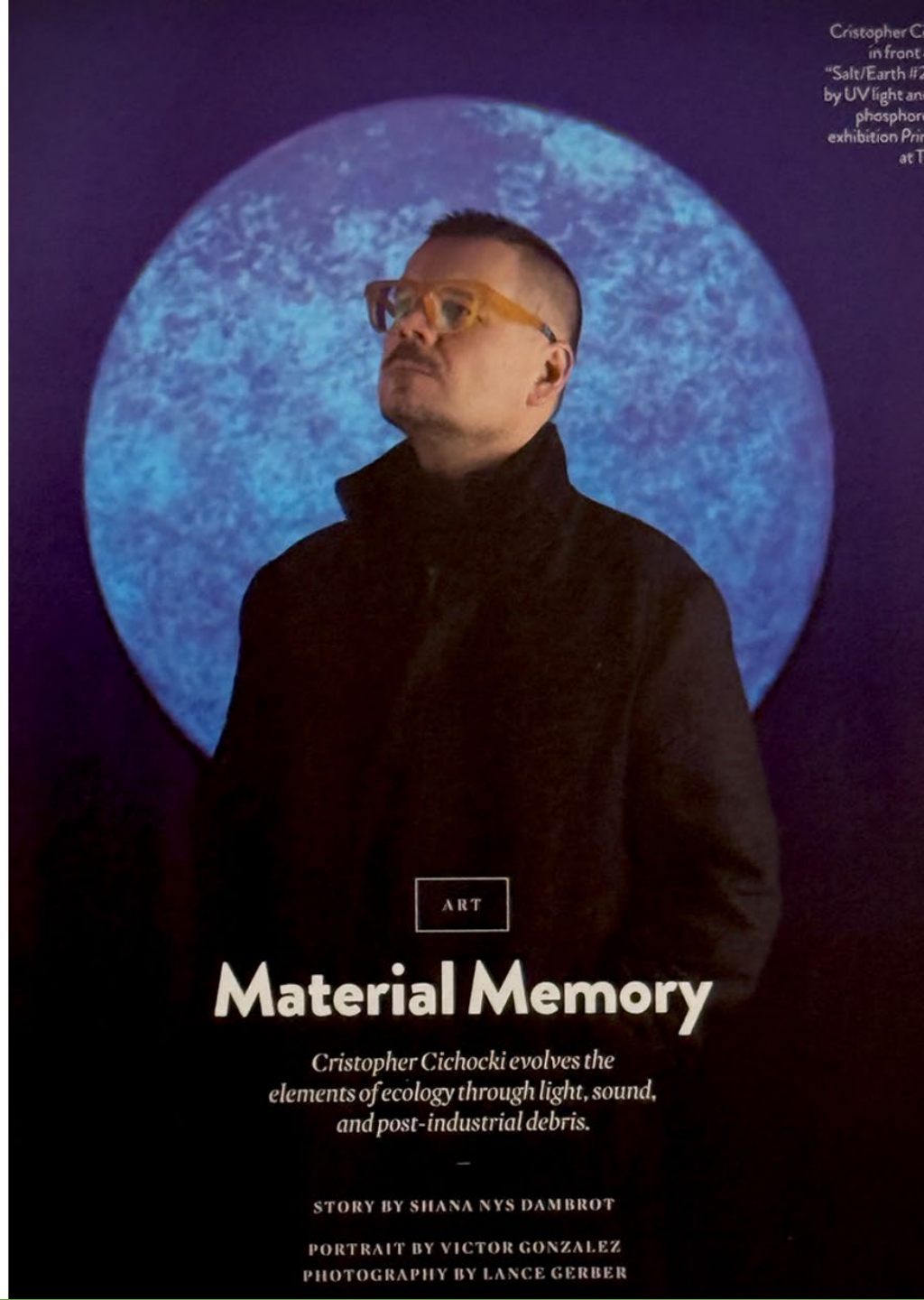

Cristopher C  
in front  
"Salt/Earth #2"  
by UV light and  
phosphor  
exhibition *Prin*  
at T

ART

## Material Memory

*Cristopher Cichocki evolves the  
elements of ecology through light, sound,  
and post-industrial debris.*

STORY BY SHANA NYS DAMBROT

PORTRAIT BY VICTOR GONZALEZ  
PHOTOGRAPHY BY LANCE GERBER







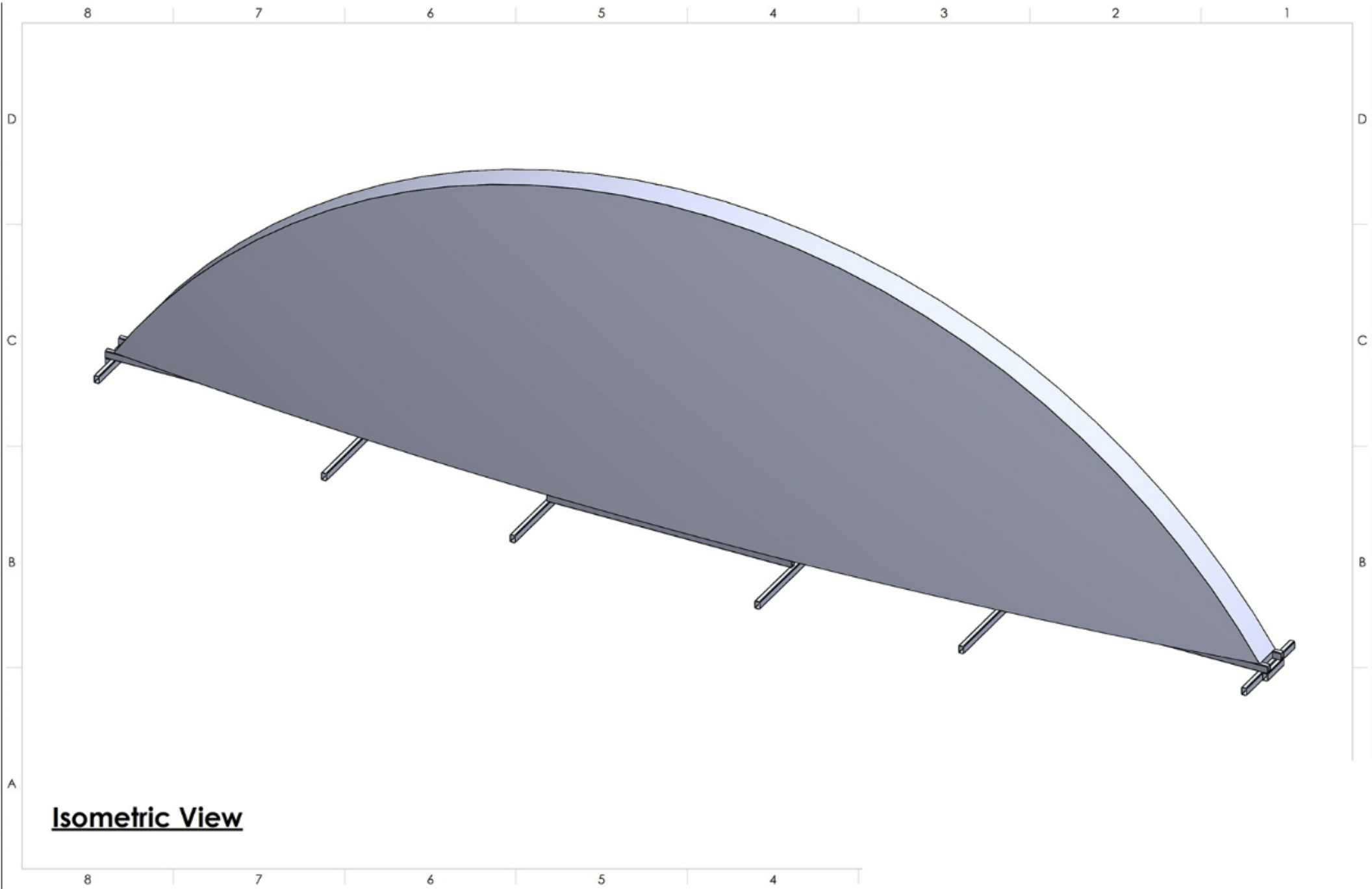

Isometric View

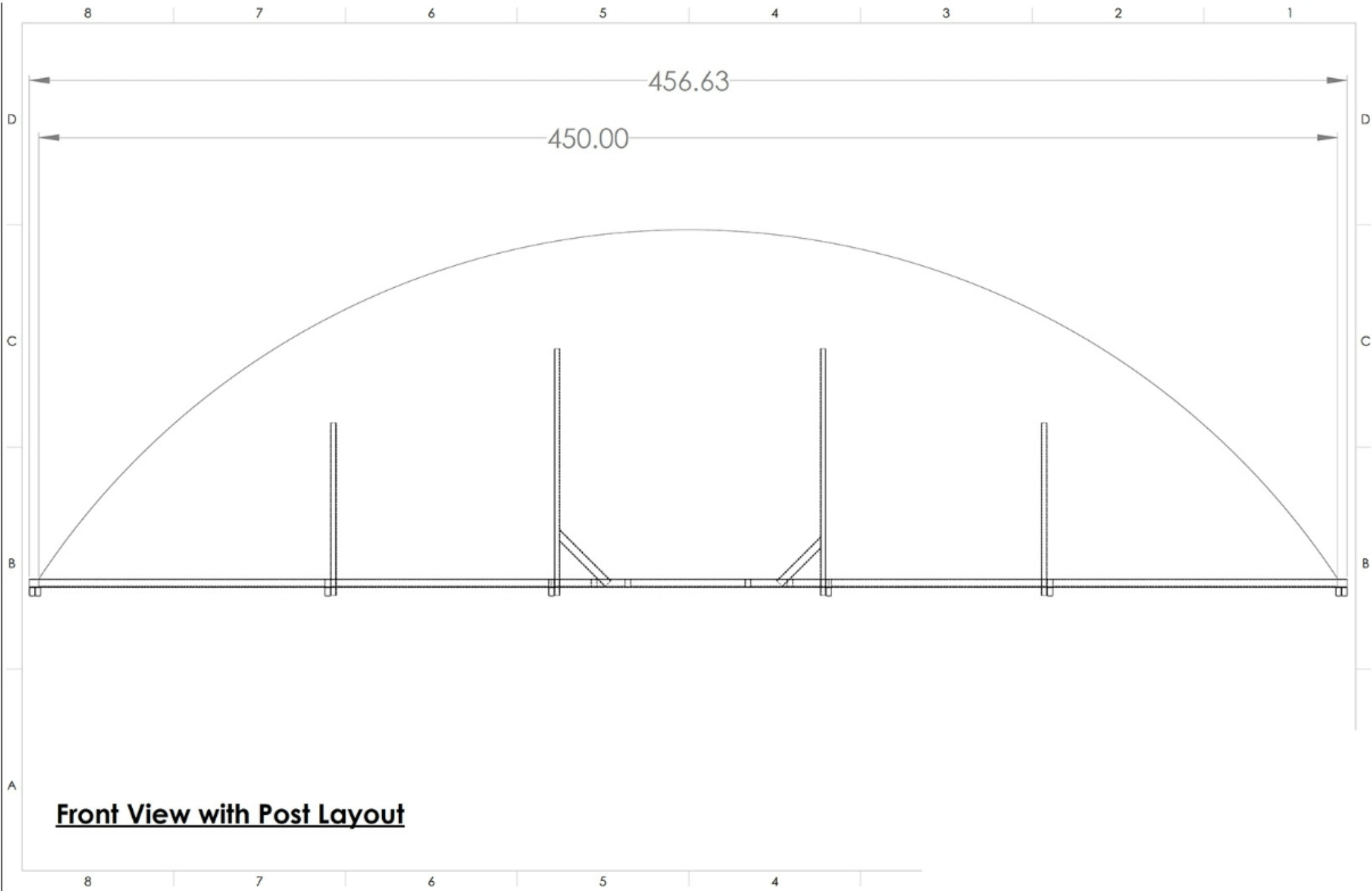

**Front View with Post Layout**

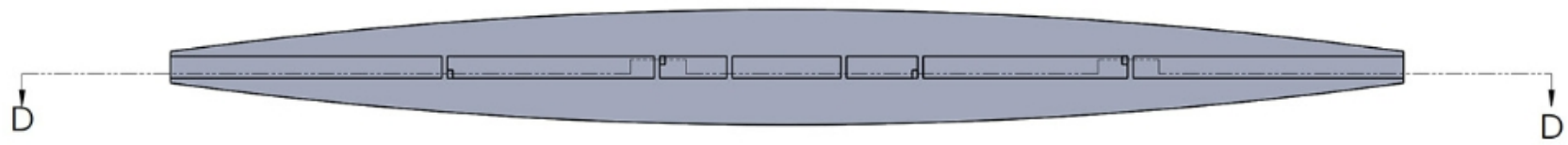
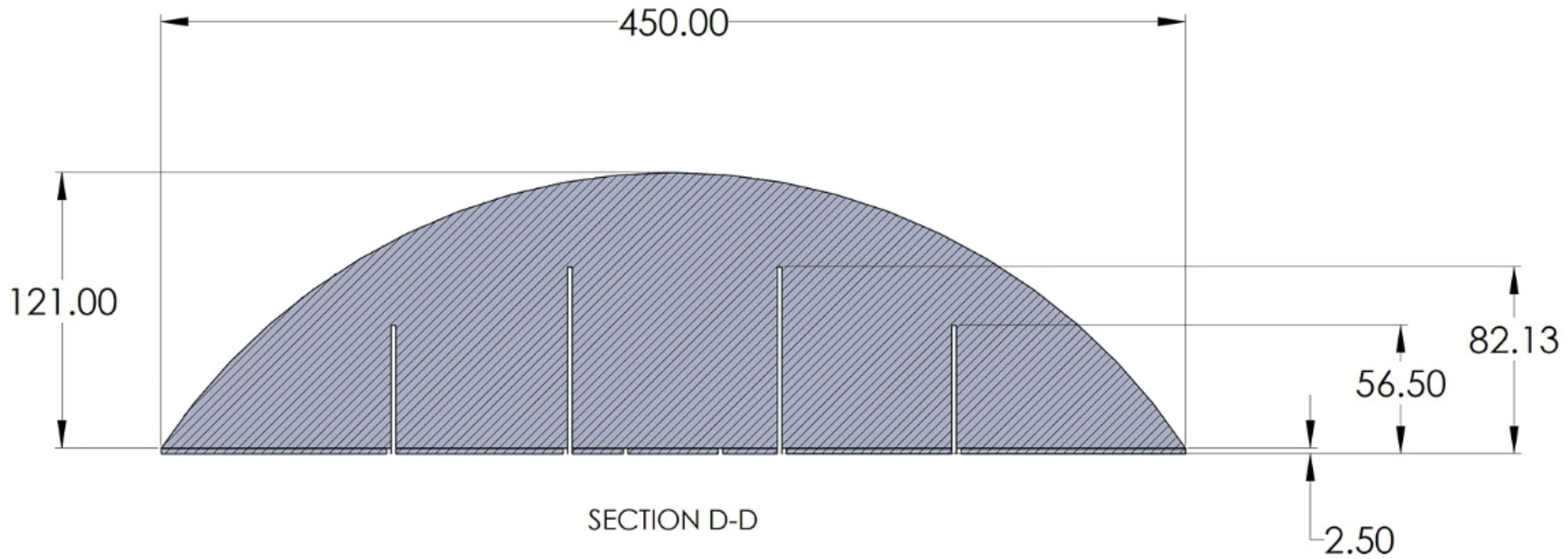

**Bottom View**

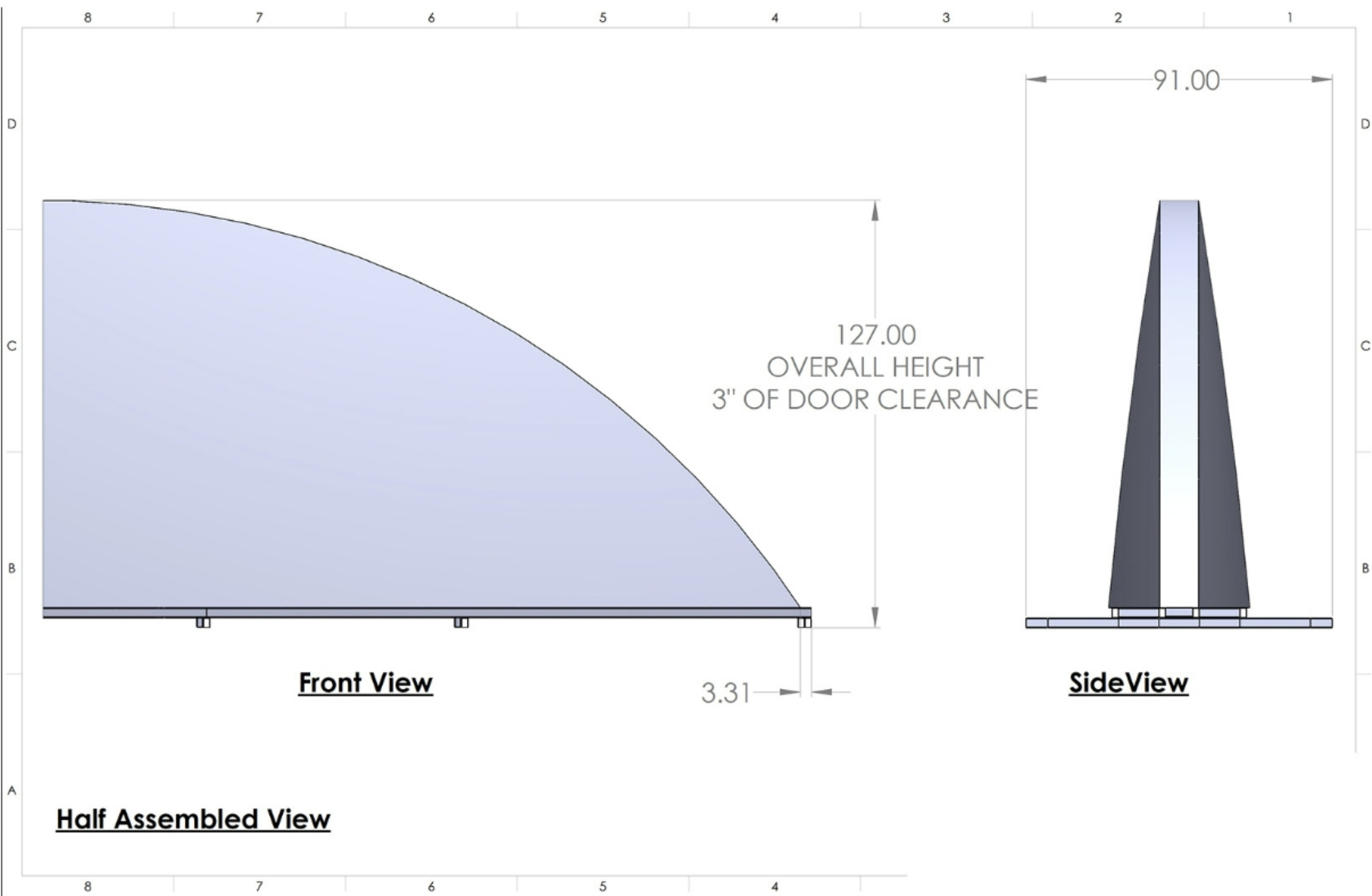

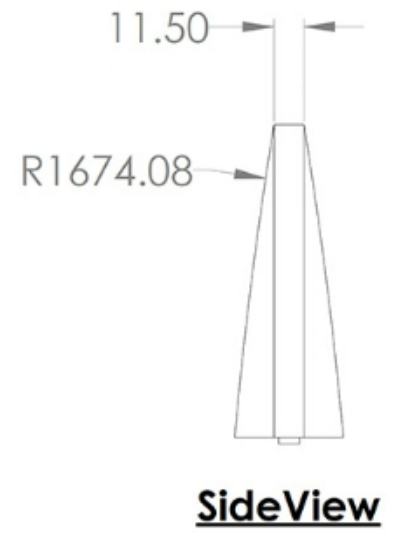
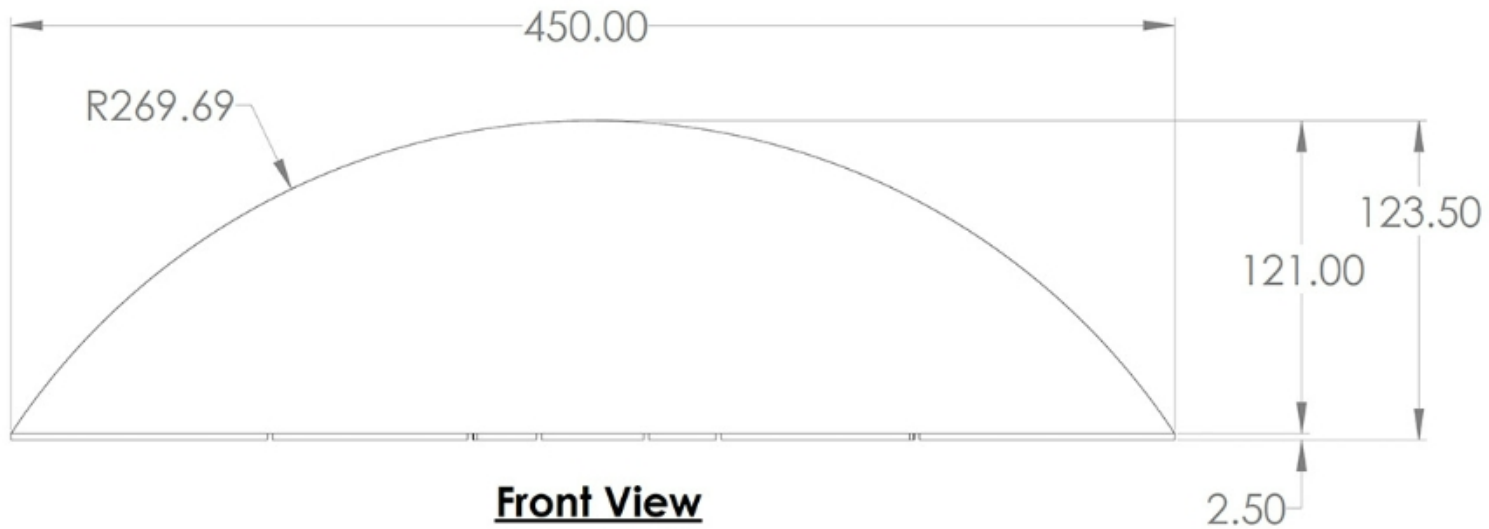
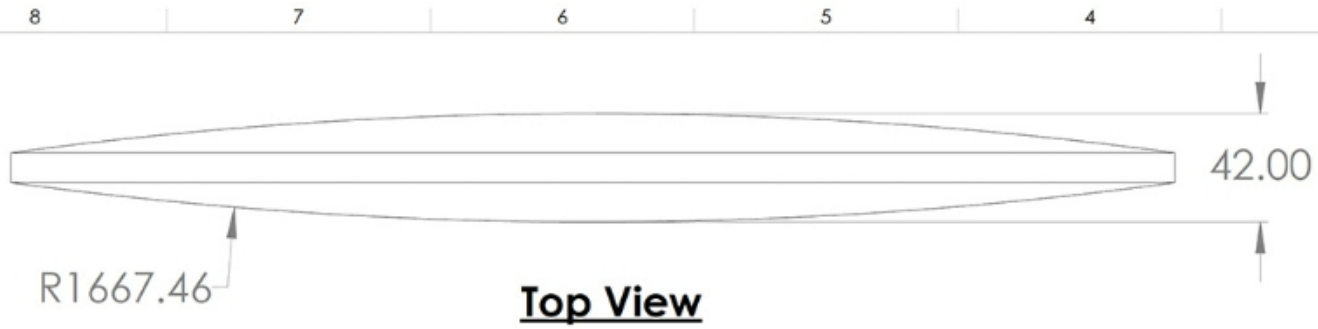



## Cristopher Cichocki (pronounced CHA-HOUSE-KEY)

### Artist bio

Cichocki studied at CalArts and Yale Norfolk School of the Art. His work is in permanent collections that include the J. Paul Getty Museum, Palm Springs Art Museum, Lancaster Museum of Art. Hailing from the Coachella Valley, Cichocki has explored the depths of the California desert over the past three decades, while generating exhibitions throughout North America, South America, Asia, and Europe. In 2014 Cichocki founded the curatorial platform Epicenter Projects that has recently partnered with Fondation L'Accolade - Institute de France to create [THE ELEMENTAL](#) - a contemporary center for the arts located in Palm Springs focused on art, science, and environment.

### SELECTED EXHIBITIONS & PERFORMANCES

2024 Inversion (solo), Saenger Galeria, Mexico City (forthcoming), NUCLEUS (solo), de Sarthe Gallery, Scottsdale, Arizona La Vision Revela lo Que El Tacto Ya Conoce, Land Rover Patria, Xappopan, Jalisco - 2023 - Fractal Traces (solo), Projecto Arte, Guadalajara, Mexico - Rising Inversion (solo), Laguna Art Museum / Art & Nature, Laguna Beach, California (solo) (forthcoming) - Primordial Water (solo), Laguna College of Art & Design Gallery, Laguna Beach, California (solo) (forthcoming) - Without Walls Festival presented by The La Jolla Playhouse & San Diego Symphony, The Rady Shell, San Diego, California - Evaporation Pools (solo), Desert Island, Rancho Mirage, California - 2022 - Desert Daze, Lake Perris, California - Coachella Music & Arts Festival, Empire Polo Field, Indio, California - The Gaia Hypothesis Chapter One: Earth, Fire, Water, Air curated by Christopher Yggdre, THE ELEMENTAL, Palm Springs, CA - When The Rubber Meets The Road, ALLEYSONME, San Bernardino, California - 2021- Nothing True Everything Is Alive curated by Christopher Yggdre presented by Fondation L'Accolade, Espace Coeur Marias, Paris, France - Historic Ground, Galerie De Vijf Ramen, Arnhem, Netherlands - 2019 - Water Memory (solo) curated by Biennale Urbana, Castello 925, Venice, Italy - 30 Days In Paris (residency), Fondation L'Accolade, Paris, France - Desert Sea (solo) Cathedral City, California - Phantom Horizons, Stuttgart International Film Festival, Stuttgart, Germany - The Wrong Digital Art Biennale, Centre del Carne Cultura Contemporània, Valencia, Spain - Rotation, The Ace, Palm Springs, California - Landworks, The Long Beach Island Foundation, Loveladies, New Jersey - Joshua Treenial, Joshua Tree, California - 2018 - Divisions of Land and Sea (solo) Museum of Art and History, Lancaster, California - BioPerversity, Nicodim Gallery, Los Angeles, California - The Paseo Project, Taos, New Mexico - Cinema Perpetuum curated by Lera Green, Minsk, Belarus - Perpetual Drone, Human Resources, Los Angeles, California - Desert Daze, Lake Perris, California - 2017 - Faultline, Mecca, California - Wake, A Ship in the Woods, Escondido, Focal Planes, Chungking Studio, Los Angeles, California - Desert Daze, The Institute of Mentalphysics, Joshua Tree, California - Desert Island, Coachella Valley Art Center, Indio, California - Dusk to Dust curated by John Knuth, Mt. San Jacinto College

Gallery, San Jacinto, California - 2016 - Biennale Urbana, Teatro Marinoni, Lido, Italy - Root Cycle (solo) Villa Angarano, Bassano del Grappa, Italy - Circular Dimensions (solo) Palm Springs Art Museum, Palm Springs, California - Open Desert, Palm Springs Art Museum, Palm Springs, California - 2015 - At The Surface (solo) Artere-A, Guadalajara, Mexico - Phantom Horizons curated by Robert Seidel, Künstlerhaus Bethanien, Berlin, Germany - Sssound Object, Mexicali Rose, Mexicali, Mexico - Experimental Video Showcase, The Drake, Toronto, Canada - Reflections On Water, Palm Springs Art Museum, Palm Springs, California - Temporary Radiation, 996 Laboratorio de Arte, Guadalajara, Mexico - Festival of Experimental Video, Museum of Moving Image, New York, New York - 2014 - Circulation (solo) Museum of Photographic Arts, San Diego, California - Škver Art Project, Klubvizija SC + MM Center Cinema, Zagreb, Croatia - Inversion (solo) Imperial Valley Art Gallery, Imperial, California - Los Angeles Film Festival, Los Angeles, California - Being Here and There curated by Sant Khalsa, Lancaster Museum of Art and History, Lancaster, California - META The Wrong New Digital Art Biennale, Galeria Municipal de Arte, Abrantes, Portugal - Summit Artist-in-Residence, Summit, Eden, Utah - Shame curated by White Zinfandel Magazine, São Paulo International Art Fair, São Paulo, Brazil - Dry Heat: Four Artists In The California Desert curated by Steven Biller, Palm Springs Fine Art Fair, Palm Springs, California - 2013 - Desert Abyss: Cycle in Cycle (solo) Palm Springs Art Museum, Palm Springs, California - Desert Abyss: Dry Capsule (solo) Palm Springs Art Museum in Palm Desert, Palm Desert, California - Epicenter (solo) See Line Gallery, Los Angeles, California - Summit Outside, Summit, Eden, Utah - 2012 - Remains In The End Times, The Popular Workshop Gallery, San Francisco, California - 2011 - Rojo Nova, Casa França-Brasil, Rio De Janeiro, Brazil - Time Based Art Festival, Portland Institute of Contemporary Art, Portland, Oregon - Multiplicity Festival, Hi Future Theatre, Rio de Janeiro, Brazil - Catalysts - 8 Artists on the San Andreas Fault, University of California Riverside, Palm Desert, California - Ende Tymes Festival, Silent Barn, Ridgewood, New York - Valley of The Ancient Lake, Salton Sea History Museum, North Shore, California - 2010 - Full Pull, Inter Arts Center, Malmö, Sweden - Rojo Nova Artsapes, Scion Building, Culver City, California - Rojo Nova, Museum of Image and Sound, São Paulo, Brazil - Desert Abyss: Origin (solo) Marks Art Center, Palm Desert, California - Plankton Robots, Fluxco, Los Angeles, California - 2008 - Elemental Shifting, Salvage Vanguard Theatre, Austin, Texas - SXSW Arts and Music Festival, Austin, Texas - 2007 - Monumento 872, Los Angeles, California - Everything Is Shifting, Pehrspace, Los Angeles, California - Druid Film Festival, Il Corral, Hollywood, California - Optical Projections, Machine Project, Los Angeles, California - 2006 - Wooster On Spring, The Candle Building, New York, New York - Turn The Screws Festival, Il Coral, Hollywood, California - 2005 - Ceremony, Bigoudi, Osaka, Japan



NEWS

## Cristopher Cichocki's 'Rising Inversion' grips viewers with phosphorescent glow



Artist Cristopher Cichocki draws lines with a flashlight on his luminescent sculpture, "Rising Inversion," the signature piece of the 11th annual Art & Nature program at north Main Beach Park in Laguna Beach on Thursday. (Don Leach / Staff Photographer)



By Andrew Turner

Staff Writer | [Contact](#)

Nov. 4, 2023 12:58 PM PT

Beachgoers who came upon it simply couldn't pass it and keep going.

A massive semicircular structure had been placed at Main Beach, due north of the boardwalk, and even in the daylight, its visitors stared perplexed.

Laguna Art Museum representatives filled them in, sharing that the scene before them was the featured exhibit for the institution's 11th annual Art & Nature program.



A crowd of guests waits to watch artist Cristopher Cichocki (in orange jacket) unveil "Rising Inversion" on Thursday. (Don Leach / Staff Photographer)

Those who could were advised to stick around for sunset, when [Coachella Valley artist](#) Cristopher Cichocki's headlining work would be officially introduced to the community.

Following a discussion by the artist to kick off the event, museum guests joined more members of the public patiently waiting to catch Cichocki's sculpture, "Rising Inversion," in full effect.

A look at the first reveal of Coachella Valley artist Cristopher Cichocki's "Rising Inversion," the featured exhibit of Laguna Art Museum's 11th annual Art & Nature program. [@TheDailyPilot](#) [@CarolCormaci](#) [pic.twitter.com/L4pBL19s90](https://pic.twitter.com/L4pBL19s90)

— Andrew Turner (@AndrewTurnerTCN) November 3, 2023

When the sun went down, Cichocki flashed a light over the sand and phosphorescent surface of the artwork, each wave of the mysterious wand-like device giving way to a new piece of what he called a "biomorphic light painting."

Gathered in the dark, a captive audience stood at rapt attention as the image came into being, its turquoise-tinted glow an homage to bioluminescence, an occurrence that happens every so often off the shore of Southern California.



Artist Christopher Cichocki's "Rising Inversion" is set against a hillside at Main Beach Park in Laguna Beach. (Don Leach / Staff Photographer)

The 3,000-pound structure, 12 feet tall and 40 feet long, dominated its location in front of a hillside above the surf line. Its depth ranged from 5 feet in the center to 1 foot at its edges, giving it a spherical appearance.

A high-density foam made the structure transportable. It was then sealed with concrete, a phosphorescent topcoat and sand from the shoreline of Laguna Beach.

While the artwork is located at Main Beach, placing it in front of the hillside and away from the downtown area was by design, Cichocki said.



Artist Christopher Cichocki begins the process of lighting his luminescent artwork "Rising Inversion" on Thursday. (Don Leach / Staff Photographer)

"The phosphorescence is a pigment that I've been using in my work for almost two decades," Cichocki said. "It's a kind of custom varnish that I've created in relationship to this phosphorescent pigment. With just a matter of 30 minutes of sunlight, it will glow all night long. If you were to have zero light pollution, this thing would be looking as bright as this particular activation of the light painting."

Cichocki considers his work to be at the intersection of the natural world and industry. In 2022, he had the opportunity to exhibit and perform at the Coachella Valley Music and Arts Festival. "Circular Dimensions x Microscape," his installation featuring 25,000 feet of PVC pipe, created a pavilion that served as his performance stage.

During its brief stay on Main Beach, "Rising Inversion" was the planned backdrop for an audiovisual performance by Cichocki on Saturday night.



Artist Cristopher Cichocki walks to his featured exhibit "Rising Inversion" on Thursday in Laguna Beach. (Don Leach / Staff Photographer)

"Circular Dimensions is my musical moniker," Cichocki said. "It's an audiovisual, ever-evolving series of performances that responds to the immediate site. I've been doing it for 10 years now, and there's always some element of sound, some element of light, of video, kind of a multi-sensory environment."

Cichocki said the sounds planned for Saturday night's show included a combination of ambient sound, Gregorian chants and sounds heard in Laguna such as ocean waves and street traffic passing by in the dead of night.

"If there's nothing around and that car's going down the vastness of Coast Highway, it actually sounds like a wave," Cichocki added. "There's this synthesis that occurs."

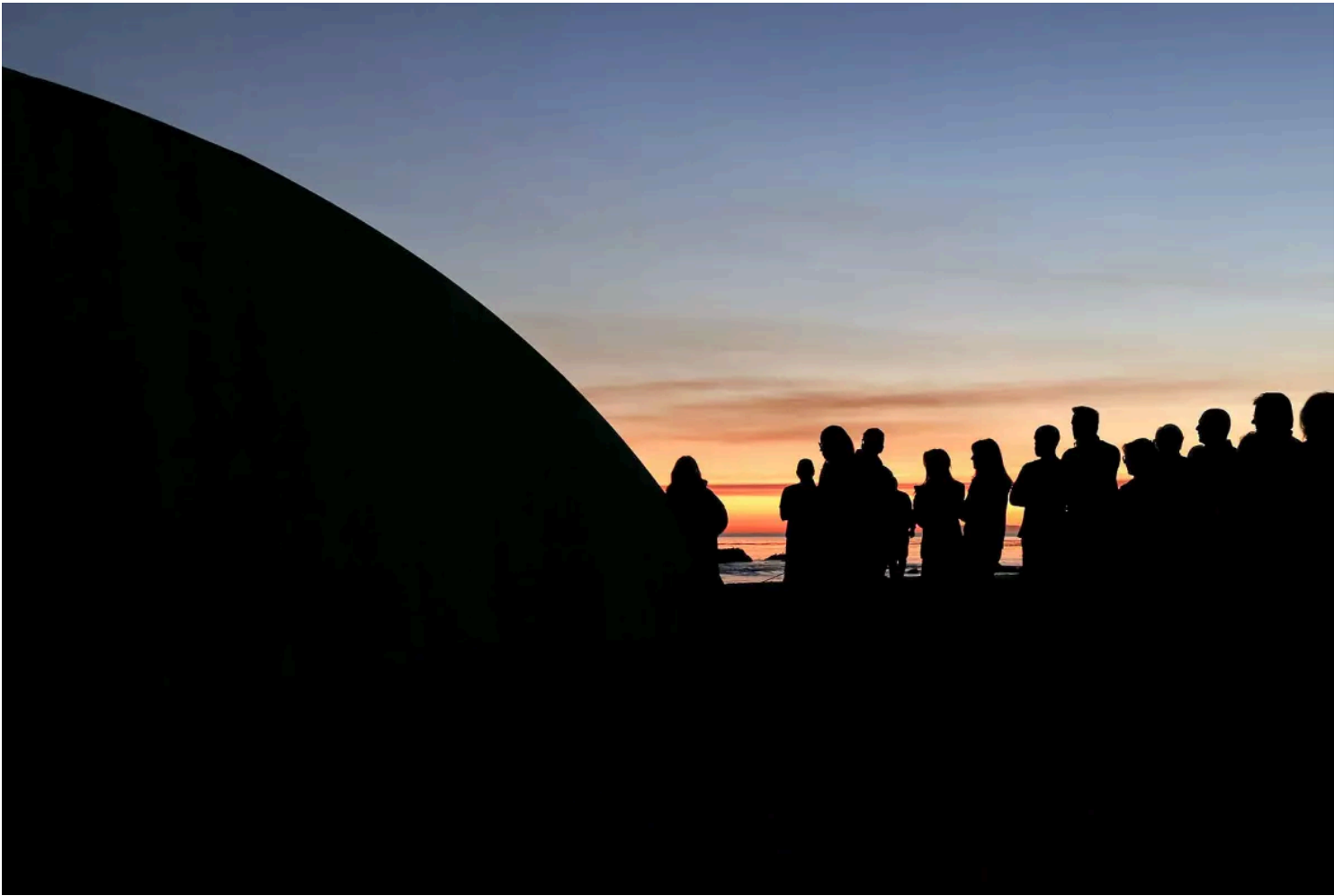

The sun sets on artist Cristopher Cichocki's "Rising Inversion" in Laguna Beach on Thursday. (Don Leach / Staff Photographer)

The final sunset for the work will fall on Sunday, which concludes this year's Art & Nature festivities.

A graduate of Palm Desert High who went on to study at California Institute of the Arts, Cichocki said it was an honor to have his work featured in the Art & Nature program. He named off several headlining artists of the past, including Laddie John Dill, Lita Albuquerque and Phillip K. Smith III.

Julie Perlin Lee, executive director of Laguna Art Museum, said she consulted with former Art & Nature artists before landing on Cichocki as this year's featured creative. She said that Cichocki had appeal as a multidisciplinary artist who had a history of being able to collaborate with multiple agencies on projects.



Artist Cristopher Cichocki draws lines with a flashlight on "Rising Inversion" at north Main Beach Park in Laguna Beach on Thursday. (Don Leach / Staff Photographer)

"What was really fascinating to me is that Cristopher is an artist who is thinking on a huge timescale," Perlin Lee said. "He thinks on geologic time, and that's something that I think is really important for me, and I hope others are picking up on that when they see his project here, that we are very concerned with our environment today and our planet today."

"So many of us are focused on the now, but I love that the undercurrent of Cristopher's work is to think about the much bigger and broader picture, and not even just in terms of water and its scarcity here on Earth, but he also talks about in his work, he thinks about how water even got onto our planet in the first place when it was being formed."



#### Andrew Turner

Andrew Turner is a sports reporter for the Daily Pilot. Before joining the Pilot in October 2016, he covered prep sports as a freelancer for the Orange County Register for four years. His work also has been used by the Associated Press and California Rubber Hockey Magazine. While attending Long Beach State, he wrote for the college newspaper, the Daily 49er. He graduated with bachelor's degrees in journalism and history. (714) 966-4611

<b>\$1,336,000</b> 3-BR at Luxury Golf Community in Palm Springs	<b>\$709,000</b> Luxury 3-BR, 2-BA, Resort Amenities in Palm Desert	<b>\$699,000</b> Modern 3-BR, 2-BA, Resort Amenities in Palm Desert	<b>New Luxury Homes</b> Palm Springs & Palm Desert <a href="#">Schedule a Tour</a>
<		>	

ARTS + CULTURE

## Local Artist Cristopher Cichocki Provides a Glimpse Inside The Elemental

Cristopher Cichocki evolves the elements of ecology through light, sound, and post-industrial debris.

May 28, 2025

Story by **Shana Dambrot**



An immersive array of light, painting, sculpture, and sound captured during Cristopher Cichocki's latest solo exhibition, Primordial Waters at The Elemental in Palm Springs.

PHOTOGRAPHY BY LANCE GERBER

Listen to this story:



00:00 

For the better part of two decades, artist Cristopher Cichocki (pronounced cha-house-key) has been mining the dried-out seabeds and decaying infrastructures of the California desert — specifically the Coachella Valley and Salton Sea regions — gathering barnacles, emergency water canisters, misshapen fish skeletons, spiny succulents, and a variety of post-industrial debris to create a unique language of ecological elegy.

His latest exhibition, *Primordial Waters* at **The Elemental** in Palm Springs, was an interdisciplinary spectacle featuring paintings, sculpture, photography, projection, sound, and immersive environments, charting a conceptual narrative from prehistoric Paleozoic to futuristic fallout. (*Primordial Waters* closed in May, but Cichocki plans to mount a follow-up in October.)



Cristopher Cichocki stands in front of his painting "Salt/Earth #2," illuminated by UV light and glowing with phosphorescence, in his exhibition *Primordial Waters* at The Elemental.

PORTRAIT BY VICTOR GONZALEZ

The Elemental itself is a fascinating node in Cichocki’s creative continuum. Founded in 2020 as a joint initiative between Cichocki and Catherine Dobler of Paris-based Fondation L’Accolade, where he was an artist in residence, the expansive space functions as a contemporary art center, residency hub, and conceptual think tank with a growing educational program for high schoolers called New Generation Arts. “I was that kid,” Cichocki often says, referring to the desert youth who now benefit from mentorship opportunities with international artists and thinkers.

Cichocki’s long-form, multiyear approach to artmaking often unfolds in chapters. He revisits sites of ecological, cultural, and geological significance – the Salton Sea, the mud pots, the San Andreas Fault (where he also ran an outdoor residency called Epicenter Projects) – relentlessly investigating the intersection of art, ecology, and material science.

**Cristopher Cichocki - Primordial Waters | PALM SPRINGS LIFE**



A CalArts graduate who relocated from Wisconsin to Palm Desert with his family at age 10, he speaks of the Coachella Valley not as *muse* but as *collaborator*. He culls organic materials, intervenes with studio artifice and technology, and presents his findings in exhibitions and performances at venues such as the **Palm Springs Art Museum** and **Lancaster Museum of Art & History** (MOAH). His resume reads like a circuit map of experimental festivals and alternative biennales, from Coachella festival's large-scale art program to Venice's Biennale Urbana, **São Paulo's Museum of Image & Sound**, Mexico City's Zona Maco, and locations closer to his Palm Springs home.

The Elemental's inaugural exhibition, *The Gaia Hypothesis – Chapter One: Earth, Fire, Water, Air* (2022), curated by Christopher Yggdre, celebrated lineages of influences and contemporaries, including Laura Grisi and Ana Mendieta, in dialogue with Cichocki's work. It explored the classical elements through James Lovelock and Lynn Margulis' 1970s theory that Earth behaves as a self-regulating organism.



Then, the group exhibition *The Gaia Hypothesis – Chapter Two: Palm Trees Also Die* (2023) examined sacred land stewardship through the lens of environmental collapse, with works addressing vanishing palm oases and the ancestral home of the Cahuilla people.



View of the entrance of the exhibition *The Gaia Hypothesis – Chapter One: Earth, Fire, Water, Air*.



Installation view of the exhibition *The Gaia Hypothesis – Chapter Two: Palm Trees Also Die*.



Series of photographs by Lance Gerber on view during the 2025 exhibition *Modern/Desert* at The Elemental.



Photography by Glen Wexler on view during the 2025 exhibition *Modern/Desert* at The Elemental.



Immersive video by artist Mona Kuhn during the 2025 exhibition *Modern/Desert* at The Elemental.

*Primordial Waters* is an evolving solo exhibition — overtly aquatic and lunar, in both material and poetic dimensions. He embraced not only the rippling blue Salton Seascape but also its hyper-salinated, post-human shimmer, encasing barnacles and debris from the shoreline in strangely alluring skins of chrome — sculptural works that read like relics of a lost civilization.

References to ancient and speculative technologies permeate the exhibition. Rusted Cold War emergency water canisters stamped “Property of the U.S. Government, 1953” rest alongside cinder blocks that evoke both brutalist fallout shelters and sacred desert architecture. Synthetic sand mingles with organic soil. Water, meant to save, instead seeps, rusts, and destroys. In his series *Evaporation Lines*, Cichocki renders old data-card topographies and patchwork grids in metallic watercolors, their surfaces catching light like liquid mercury. A cavernous black-light chamber cycles between daylight neutrals and hallucinogenic nocturnes, making the works appear to shape-shift under UV spectra. At their core, they remain abstract, cosmic, molecular — fractal inversions of neurons, root systems, and galactic clusters.

There’s a robust art historical lineage here, one that includes light and space artists like Mary Corse and **Lita Albuquerque**, land art figures Robert Smithson and Nancy Holt, Vivian Suter’s canvas jungles, and Walter De Maria’s boxes of soil, bringing the vast terrain into human space and scale. Cichocki, too, brings the land inside — not only as material but as living, unpredictable systems. “We live not, in reality, on the summit of a solid earth, but at the bottom of an ocean of air,” he reminds us, citing Thales of Miletus’ prescient 600 B.C. observation on the intersection of natural science and human perception. Cichocki’s art translates that invisible connection into strikingly visible form.



Cichocki's *Fractal Traces* series of works on paper alongside his painting series *Evaporation Lines*, as seen in *Primordial Waters*.



His paintings and sculptural works embedded with sea salt, sand, and barnacles, as seen in *Primordial Waters*.

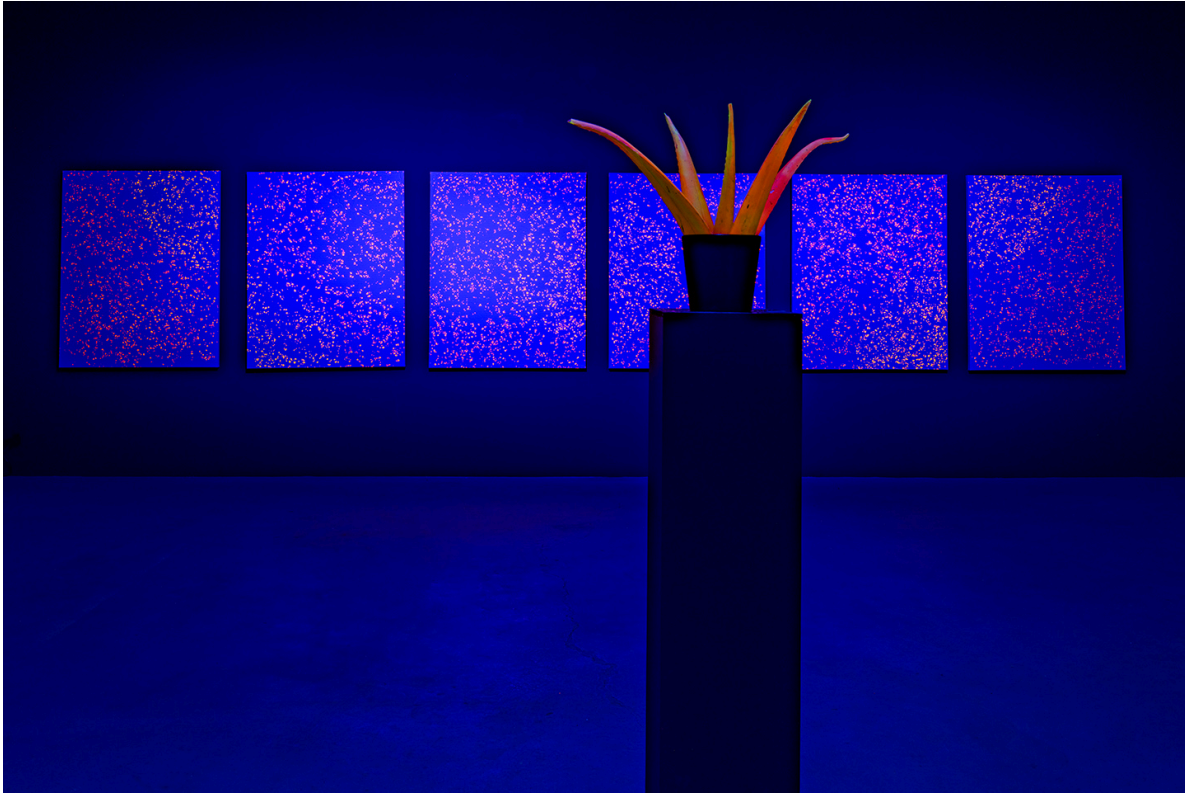

Black-light causes a resin-cast aloe vera installation to glow in *Primordial Waters*.

Beyond the objects in the show, *Primordial Waters* comes alive through time-based elements. Video projections mimic lunar surfaces and phosphorescent marine life. A live microscope laboratory captures barnacles growing and mutating in real time. Audiovisual performances activate the space with soundscapes and ritual interventions. A resin-cast, Day-Glo aloe vera installation nods to both psychedelic bioluminescence and the practical vernacular of desert survival — and recalls the gorgeous and alarming impact of Cichocki’s earlier works.

Through *The Elemental*, Cichocki and Dobler have institutionalized their ethos. To date, more than 50 international artists have exhibited there, while high school mentees thread their own narratives into the desert’s cultural tapestry. An annual residency program has brought practitioners like Sara Favriau, Marie-Luce Nadal, and Mona Kuhn into direct engagement with the region’s ecology. An upcoming expansion promises additional exhibition and performance space.

There’s a larger cosmology at work here — one where the desert is both graveyard and laboratory, where water is older than the sun, and where art might still function as witness and warning.

SHARE THIS STORY

Proposed location for installation of *Rising Inversion* – Ironwood Park, 47800 Chia Drive





View from concrete path in park.



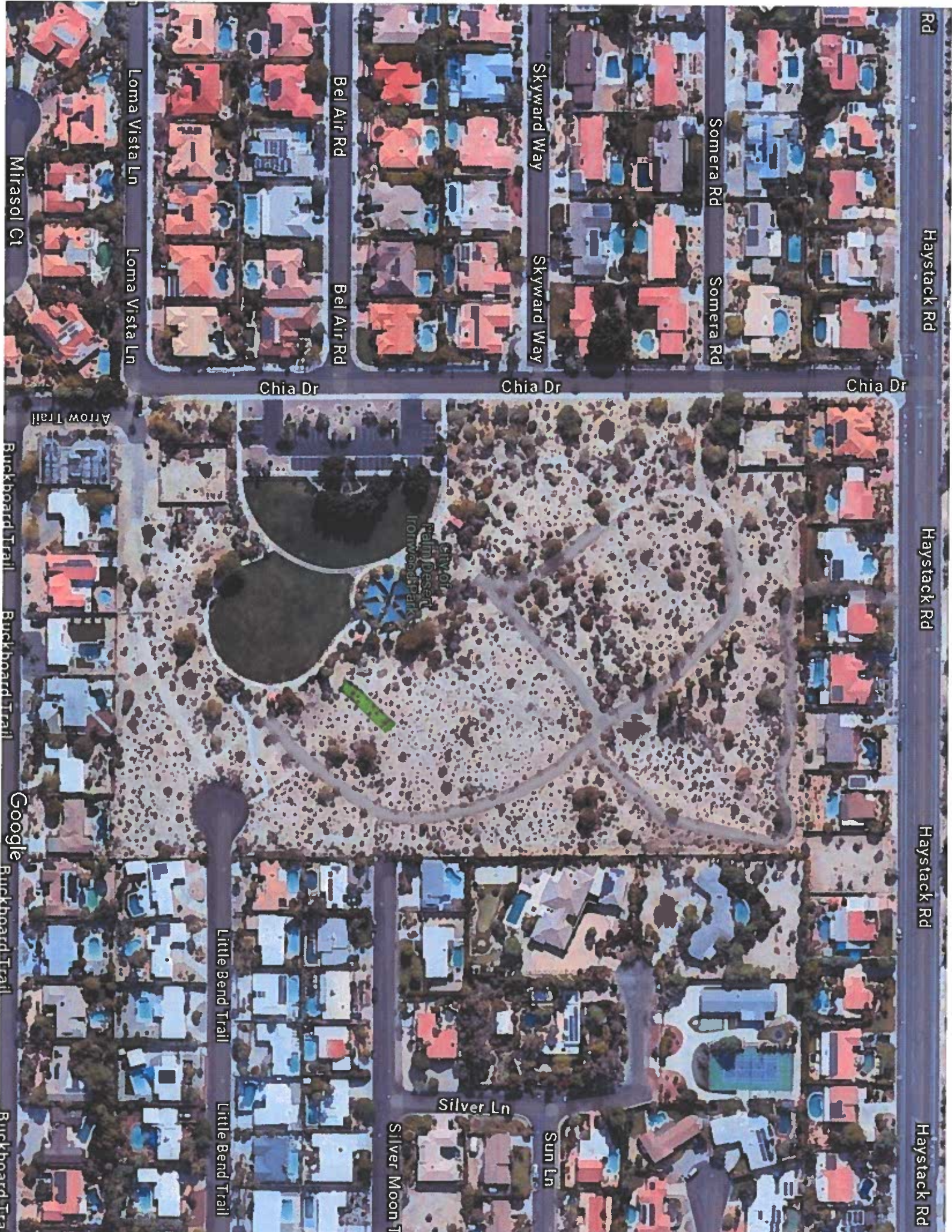

Rd

Haystack Rd

Haystack Rd

Haystack Rd

Haystack Rd

Somera Rd

Somera Rd

Skyward Way

Skyward Way

Bel Air Rd

Bel Air Rd

Loma Vista Ln

Loma Vista Ln

Mirasol Ct

Chia Dr

Chia Dr

Chia Dr

Arrow Trail

Buckboard Trail

Buckboard Trail

Google

Buckboard Trail

Buckboard Tra

Little Bend Trail

Little Bend Trail

Silver Ln

Silver Moon T

Sun Ln