

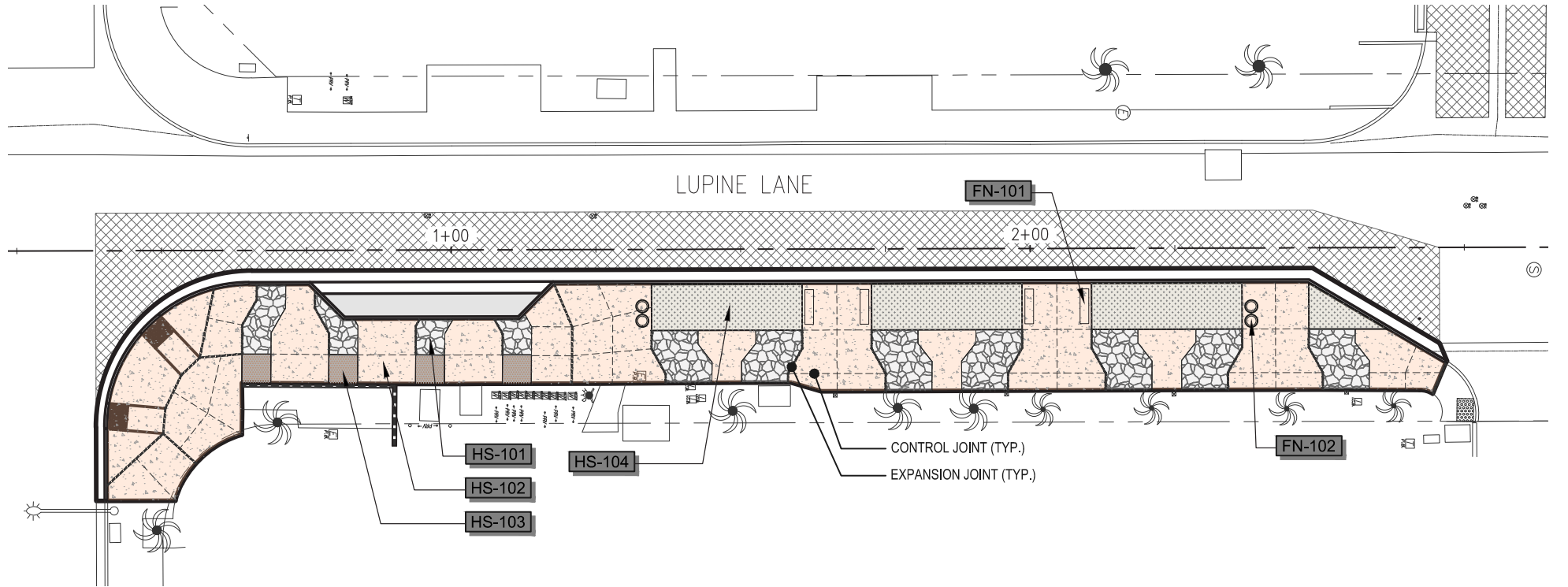



LUPINE LANE

SITE IMPROVEMENTS LUPINE LANE



HARDSCAPE PLAN



HARDSCAPE SCHEDULE

SYMBOL	DESCRIPTION	QTY
 HS-101	CONCRETE W/ DECORATIVE FLAGSTONE STAMPING FLAGSTONES W/ HAND CHISELED EDGES GROUPED IN RANDOM FORMATION (48"X48" STAMP SIZE)	761 sf
 HS-102	INTEGRAL COLOR CONCRETE SIKACOLOR U12 SUNSET BEIGE, OR APPROVED EQUAL	2,432 sf
 HS-103	TREE PLANTER W/ STABILIZED AGGREGATE FINISH	100 sf
 HS-104	DECOMPOSED GRANITE (DG) PLANTER	678 sf

FURNISHING SCHEDULE

SYMBOL	DESCRIPTION	QTY
 FN-101	WAUSAU TILE, SWEEP BENCH ZB.SW.01., 6 FT CONCRETE BENCH, FREE STANDING, COLOR: WEATHERSTONE W30 STAR	4
 FN-102	WAUSAU TILE, CONC. TRASH RECEPTACLE W/ ALUMINUM TOP TF1082, 31 GAL, COLOR: WEATHERSTONE W30 STAR TRASH RECEPTACLE LID COLOR: 8 BLACK RECYCLING RECEPTACLE LID COLOR: 0 BLUE	4

EXISTING CONTEXT + CHARACTER





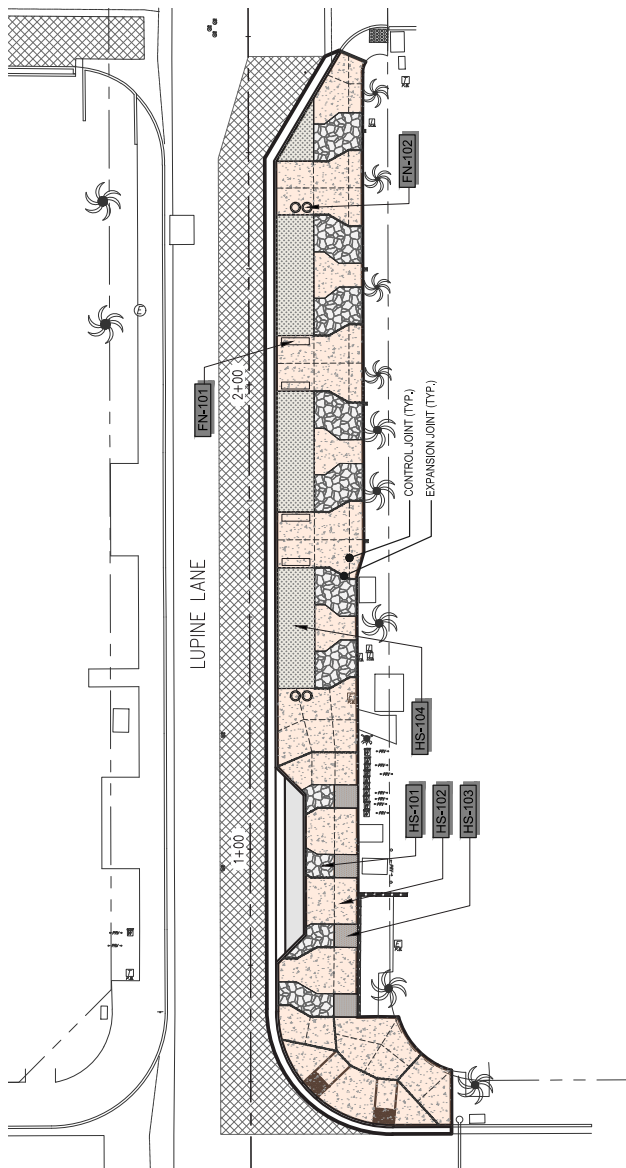

HARDSCAPE PALETTE

HARDSCAPE PLAN



HARDSCAPE SCHEDULE

SYMBOL	DESCRIPTION	QTY
 HS-101	CONCRETE W/ DECORATIVE FLAGSTONE STAMPING FLAGSTONES W/ HAND CHISELED EDGES GROUPED IN RANDOM FORMATION (48"X48" STAMP SIZE)	761 sf
 HS-102	INTEGRAL COLOR CONCRETE SIKACOLOR U12 SUNSET BEIGE, OR APPROVED EQUAL	2,432 sf
 HS-103	TREE PLANTER W/ STABILIZED AGGREGATE FINISH	100 sf
 HS-104	DECOMPOSED GRANITE (DG) PLANTER	678 sf



CITY SHALL FURNISH IW OF ANY CITY-STANDARDS THE CITY WISHES TO USE FOR THESE IMPROVEMENTS IN LIEU OF THE PROPOSED PALETTE;
CITY SHALL APPROVE OR DENY PROPOSED MATERIALS AND COLOR SELECTIONS.

FURNISHING PALETTE

HARDSCAPE PLAN

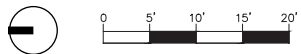
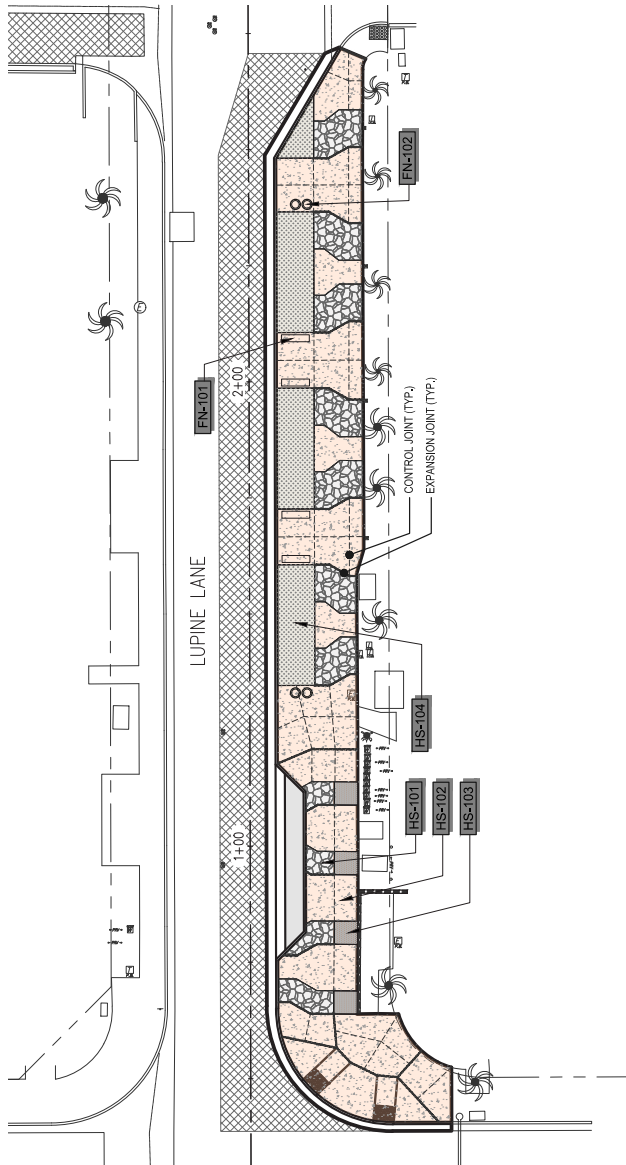

FURNISHING SCHEDULE

SYMBOL	DESCRIPTION	QTY
▭	FN-101 WAUSAU TILE, SWEEP BENCH ZB,SW,01,, 6 FT CONCRETE BENCH, FREE STANDING, COLOR: WEATHERSTONE W30 STAR	4
○	FN-102 WAUSAU TILE, CONC. TRASH RECEPTACLE W/ ALUMINUM TOP TF1082, 31 GAL, COLOR: WEATHERSTONE W30 STAR TRASH RECEPTACLE LID COLOR: 8 BLACK RECYCLING RECEPTACLE LID COLOR: 0 BLUE	4

FN-101



FN-102



FURNISHING PROPOSED TO BE REVIEWED AND APPROVED BY CITY; IF CITY DESIRES ANY STANDARD FURNISHING THE CITY SHALL ISSUE TO IW THE APPROPRIATE MANUFACTURER AND MODEL NUMBERS.

FURNISHING PALETTE

FN-101

BENCHES



phone 800.388.8728 | mail wtile@wausautile.com | wausautile.com

BENCH SWEEP

SHAPE

To match there is also a bench Sweep with length 48" available

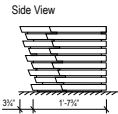

Top View

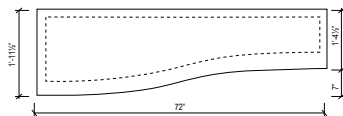

Front View

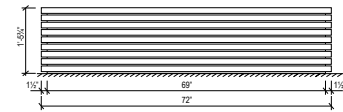

HANDLING*

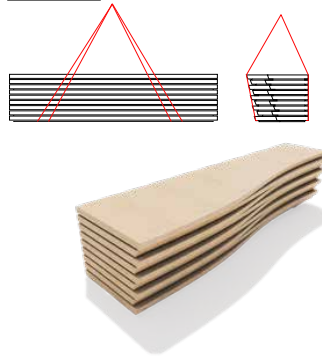

DESIGNER



Markus Kurkowski

Element	Length inch	Width inch	Height inch	Weight lbs/p
ZB.SW.01	72	varies	17 3/4	1,030 - 2,065

! Special custom manufacturing. Order and delivery time on request

PRODUCT DESCRIPTION

Characteristics

- Prefabricated concrete element
- Finish:
 - Acid wash : a light acid etch finish with an even and flat texture across the entire surface
 - Weatherstone : a sandblast finish exposing rock and giving a subtle texture and weathered look
 - Ground & polished: a flat, smooth and polished surface with exposed rock and matrix
- Free standing
- Factory sealed

Delivery information

- Delivery only on pallets

PROJECT STUDY INFORMATION

- Specific dimensions in custom manufacturing (only on order): on demand

SHIPPING FEES

- On demand

COLORS

Acid wash	Weatherstone	Ground & Polished
A20 - White	W20 - White	G20 - White
A21 - Buff	W21 - Buff	G21 - Buff
A22 - Sand	W22 - Sand	G22 - Sand
A23 - Gray	W23 - Gray	G23 - Gray
A24 - Brick red	W24 - Brick red	G24 - Brick red
A25 - Brown	W25 - Brown	G25 - Brown
A26 - Charcoal	W26 - Charcoal	G26 - Charcoal
A30 - Star	W30 - Star	G30 - Star
A31 - Fog	W31 - Fog	G31 - Fog
A38 - Night	W33 - Misty gray	G33 - Misty gray
	W38 - Night	G38 - Night

FN-102

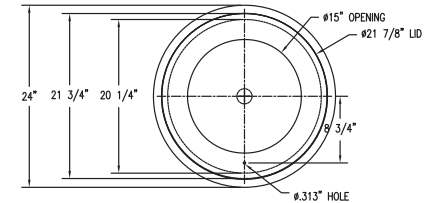

1 TOP VIEW OF TF1840 WASTE CONTAINER
SHOWN WITHOUT LID Scale: 1/8" = 1"

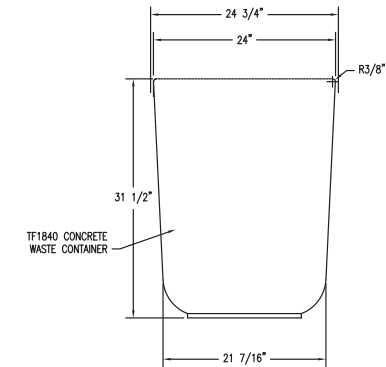

2 ELEVATION VIEW
Scale: 1/8" = 1"

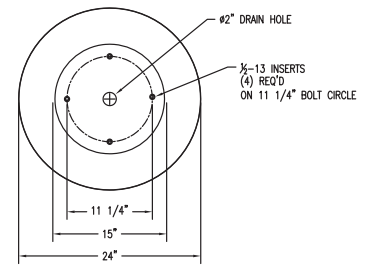



3 BOTTOM VIEW
Scale: 1/8" = 1"

LANDSCAPE PALETTE

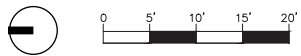
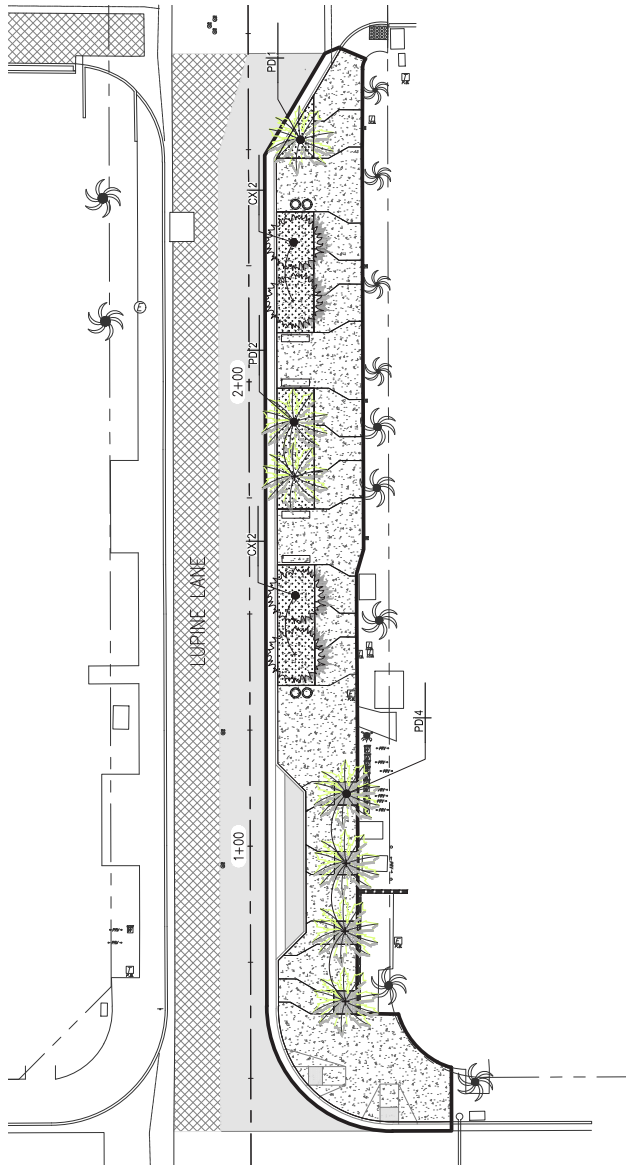
PLANTING PLAN



PLANT SCHEDULE

SYMBOL	CODE	QTY	BOTANICAL / COMMON NAME
TREES			
	CX	4	Cercidium x 'AZT' AZT Thornless Palo Verde
	PD	7	Phoenix dactylifera Date Palm

 UNDERSTORY PLANTING AREA: 680 SF

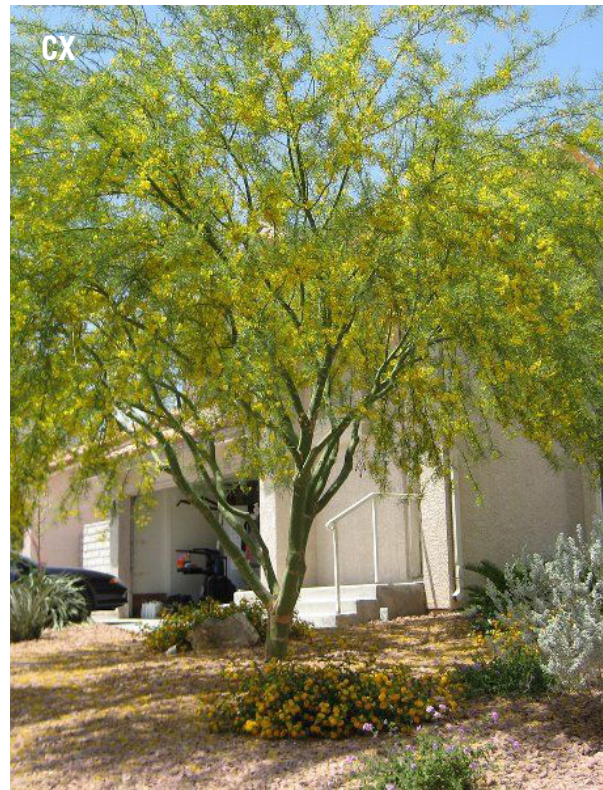

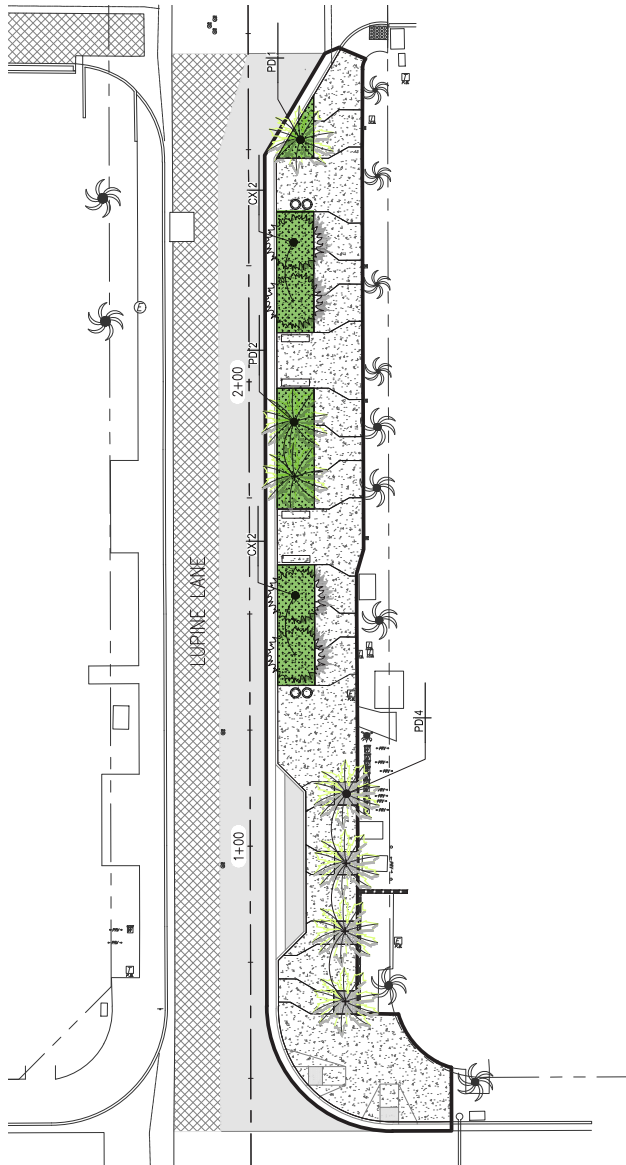

LANDSCAPE PALETTE

PLANTING PLAN



PLANT SCHEDULE

SYMBOL	CODE	QTY	BOTANICAL / COMMON NAME
TREES			
	CX	4	Cercidium x 'AZT' AZT Thornless Palo Verde
	PD	7	Phoenix dactylifera Date Palm

 UNDERSTOREY PLANTING AREA: 680 SF

